

AN-915 Automotive Physical Layer SAE J1708 and the DS36277

ABSTRACT

The purpose of this application report is to give a general understanding of the J1708 recommended practice (SAE J1708) and the DS36277 transceiver that is optimized for use with Society of Automotive Engineers (SAE) J1708. Additionally, this document explains the significant differences between the DS36277 and a standard RS-485 transceiver, the DS75176B.

Contents

1	Introduction	2
2	Explanation of Terms	2
3	Definition of TIA/EIA-485 and SAE J1708	2
4	The Society of Automotive Engineers (SAE) Recommended Practice J1708	2
5	J1708 Bus Loading	3
6	Dominant Mode	4
7	Features of the DS75176B	5
8	Features of the DS36277	5
9	Conclusions	5
10	References	6

List of Figures

1	Automobile Controls on a SAE J1708 Bus	2
2	Character Format	3
3	Node Load Circuit.....	3
4	The DS75176B in a SAE J1708 Application	4
5	The DS36277 in a SAE J1708 Application	4
6	Typical SAE J1708 System Block Diagram	4
7	SAE J1708 Typical Bus Configuration and Loading.....	5

List of Tables

1	Definition of RS-485 and SAE J1708.....	2
---	---	---

1 Introduction

Multiplex (MUX) wiring, or networking, has been introduced in automotive applications to address the increase in complexity and the number of onboard electronic devices in automobiles. Both standardized and proprietary solutions exist to address these issues. A standardized approach may be more desirable as cost and interoperability become important factors to consider for all original equipment manufacturers including automobile manufacturers.

2 Explanation of Terms

- Dominant Mode – This is a mode of operation in which one logic state is dominant over any other state on the bus.
- Listen Mode – This is a mode of operation in which a receiver is always active (assuming the device is powered) and its output is always in a known state.

3 Definition of TIA/EIA-485 and SAE J1708

This section explains the definition of TIA/EIA-485 (RS-485) and SAE J1708. However, it does not explain the electrical characteristic specifications of RS-485 or SAE J1708. The provisions for SAE J1708 are discussed in [Section 4](#) and for a brief definition of the RS-485 electrical specifications, see *AN-216 Summary of Well Known Interface Standards (SNLA138)*.

First, RS-485 is an interface standard that specifies only electrical characteristics for balanced multipoint interface circuits. A complete interface standard will specify electrical, mechanical, and functional characteristics as does the popular interface standard TIA/EIA-232-E (see [Table 1](#)). Second, SAE J1708 specifies only the functional characteristics for balanced interface circuits. RS-485 is referenced by SAE J1708 for its electrical specifications but with a few modifications. Therefore, the end designer of a SAE J1708 application must specify their own mechanical connections.

Table 1. Definition of RS-485 and SAE J1708

	Mechanical	Functional	Electrical
TIA/EIA-485			✓
SAE J1708		✓	REF. RS-485
TIA/EIA-232-E	✓	✓	✓

4 The Society of Automotive Engineers (SAE) Recommended Practice J1708

The SAE has defined this recommended practice for serial data communications between microcomputer systems in heavy duty vehicle applications. It is also well suited to passenger car applications (as shown in [Figure 1](#)) and many non-automotive uses. The bus is expected to be used for sharing data. An applications document, like SAE J1587 or SAE J1922, defines the actual data or functions to be transmitted. SAE J1708 only defines the hardware and basic software.

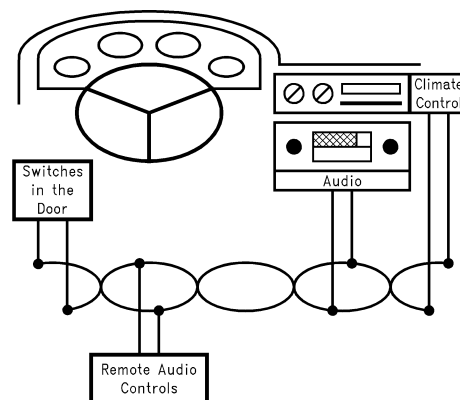

Figure 1. Automobile Controls on a SAE J1708 Bus

The physical media is a two-wire bus using 18-gauge twisted pair with a minimum of 1 twist per inch. The maximum length is intended to be 40m. A maximum of 20 nodes is specified. Deviations from this must be carefully analyzed to determine impact on bus performance over the entire operating range.

Each node may access the bus randomly once the bus is idle for a predetermined access time. If two or more nodes attempt to access the bus at the same time, the contending nodes must arbitrate for the bus. Arbitration is determined by priority, which is set between 1 (top priority) and 8. An applications document will reference SAE J1708 and define the priority associated with each message. Since there can be up to 20 nodes, it is possible for two contending nodes to have the same priority. When contention exists between two or more nodes, arbitration is determined by the bus access time. This is the time a node is required to wait before it can attempt to access the bus.

The protocol is consistent with standard universal asynchronous receiver/transmitter (UART) operation. A message consists of a message identification character (MID), a data character(s) and a checksum character. The total message length should not exceed 21 characters. A character is defined as 10 bits: the first bit is always the start bit (logic level LOW), followed by eight bits of data and, the tenth bit is the stop bit (logic level HIGH) (see Figure 2).

The bit timing equates to a baud rate of 9600. The logic LOW and HIGH levels are encoded as “dominant” and “recessive”, which is described later. The hardware is defined by the RS-485 standard for its electrical characteristics, with some exceptions and modifications.

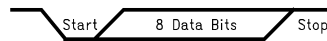

Figure 2. Character Format

5 J1708 Bus Loading

The recommended implementation for a SAE J1708 load is shown in Figure 3. The recommended implementation for a SAE J1708 system using a standard RS-485 transceiver, such as the DS75176B (see Figure 4), is shown in Figure 7. The circuitry between the bus and the transceiver differs from RS-485 and is intended to provide several features:

- R1 and R2 provide the bias for the “recessive” state.
- C1 and C2 combine to form a 6 MHz low-pass filter, effective for reducing FM interference.
- R2, C1, R4 and C2 combine to form a 1.6 MHz low-pass filter, effective for reducing AM interference.
- Since the bus is unterminated, at high frequencies R3 and R4 perform a pseudo-termination. This makes the implementation more flexible as no specific “termination nodes” are required at the ends of the bus.

The resistor and capacitor values are as follows and are shown in Figure 3:

- Resistor 1 and 2 (R1 and R2)— 4.7 k Ω
- Resistor 3 and 4 (R3 and R4)— 47 Ω
- Capacitor 1 and 2 (C1 and C2)— 2.2 nF

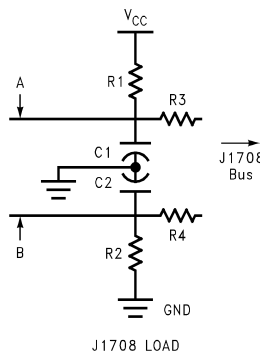

Figure 3. Node Load Circuit

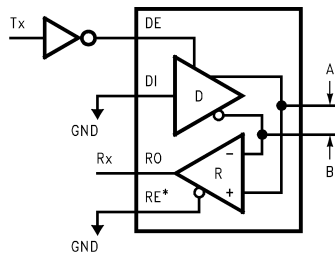

Figure 4. The DS75176B in a SAE J1708 Application

6 Dominant Mode

The drivers used by SAE J1708 are used in a dominant mode application. The driver's input (DI) is tied LOW and the signal (Tx) to be transmitted is tied to the driver's enable. The enable (DE) is active HIGH for the DS75176B while the enable (DE*) for the DS36277 is active LOW. First, this information is very important because this tells us that the driver is only capable of driving LOW. Therefore, a logic level LOW is encoded as "dominant". When the driver is disabled, the bus is pulled high by external bias resistors R1 and R2 (as shown in Figure 3). Therefore, a logic level HIGH is encoded as "recessive". Second, if the driver's enable is active LOW, then you will transmit positive logic. But, if the driver's enable is active HIGH you will transmit negative logic. SAE J1708 is only defined for positive logic. Therefore, to implement a SAE J1708 application using DS75176B, which has an active HIGH driver enable, an inverter is needed for the driver enable (see Figure 4 and Figure 6). However, the active LOW driver enable pin on the DS36277 saves you an externally needed inverter (see Figure 5).

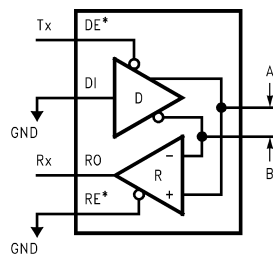

Figure 5. The DS36277 in a SAE J1708 Application

In the case of a SAE J1708 application, a logic LOW can overwrite a logic HIGH. Therefore, if contention exists between two drivers with transmitting signals (Tx) in opposite states, the driver driving the "dominant" state wins.

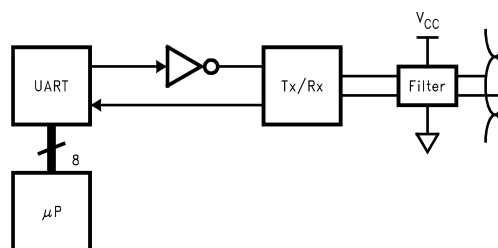

Figure 6. Typical SAE J1708 System Block Diagram

SAE J1708 requires all receivers to listen to every message identification character transmitted to determine if contention exists. Unlike the driver, the receiver's enable (RE*) is always tied LOW (see Figure 4 and Figure 5). This means the receiver is always in listen mode (see Explanation of Terms).

The external components shown in Figure 3 provide the necessary bias for a logic High "recessive" state. SAE J1708 requires no additional external components other than the J1708 load. This means that no parallel termination can be used at the ends of the SAE J1708 bus. The required loading also provides failsafe protection.

7 Features of the DS75176B

The DS75176B offers full compliance with the RS-485 standard and it is compatible with RS-422 and V.11. The device is available with industrial temperature range. Additionally, a thermal shutdown circuit protects the device against thermal overstress due to excessive power dissipation. Furthermore, the receiver has failsafe protection. However, the receiver's output is only guaranteed to be in a logic HIGH state for an open input line condition. The receiver also has ± 200 mV threshold levels. The driver has an active HIGH enable while the receiver has an active LOW enable.

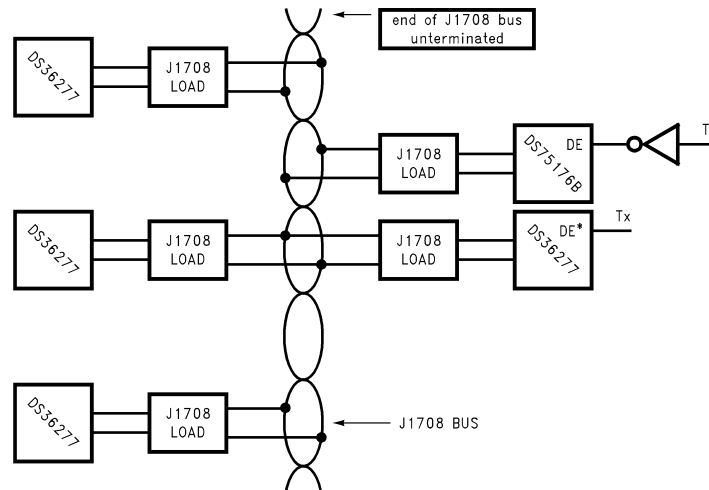

Figure 7. SAE J1708 Typical Bus Configuration and Loading

8 Features of the DS36277

The DS36277 is optimized for use with SAE J1708 electrical applications and the device is still compatible with RS-485, RS-422, and V.11 standards. Like the DS75176B, the device is available with industrial temperature range. Also the device includes thermal shutdown protection; plus the receiver has failsafe protection. Additionally, the receiver has full failsafe defenses that includes shorted and terminated line fault and conditions as well as open line conditions. The receiver's output is assured to be in a logic HIGH state for all three line faults and conditions. The receiver's 0 V to -500 mV threshold provides the protection from shorted line faults. Unlike the DS75176B, both the driver and the receiver have an active LOW enable.

The DS36277 also has a very rugged ESD structure that allows it to withstand electrostatic discharges (ESD) up to 7 kV (HBM). The device is also available in SOIC as well as DIP packages.

9 Conclusions

Selecting an established physical layer such as J1708 can eliminate many of the challenges of designing a serial communications system. The dominant mode operation allows for a non-destructive arbitration scheme.

J1708 is based on RS-485 electrical specifications and benefits from the ruggedness, low cost and availability of compliant ICs are already on the market.

The DS36277 transceiver has been optimized for J1708. It provides failsafe protection against bus faults and eliminates the need for an external inverter.

This application report provides a brief overview of the recommended practice and the interface standard. It is highly recommended to carefully review the complete documents. The documents can be obtained from:

SAE, 400 Commonwealth Dr.
Warrendale, PA 15096-0001
Global Engineering Documents
2805 McGraw Avenue
P.O. Box 19539
Irvine, CA 92174

10 References

- *AN-216 Summary of Well Known Interface Standards* ([SNLA138](#))
- EIA RS-485, Standard for *Electrical Characteristics of Generators and Receivers for use in Balanced Digital Multipoint Systems*, Electronic Industries Association Engineering Department. Washington D.C. 1983.
- SAE J1708, *Serial Data Communications Between Microcomputer Systems In Heavy Duty Vehicle Applications*. Society of Automotive Engineers. 1990.

IMPORTANT NOTICE

Texas Instruments Incorporated and its subsidiaries (TI) reserve the right to make corrections, enhancements, improvements and other changes to its semiconductor products and services per JESD46, latest issue, and to discontinue any product or service per JESD48, latest issue. Buyers should obtain the latest relevant information before placing orders and should verify that such information is current and complete. All semiconductor products (also referred to herein as "components") are sold subject to TI's terms and conditions of sale supplied at the time of order acknowledgment.

TI warrants performance of its components to the specifications applicable at the time of sale, in accordance with the warranty in TI's terms and conditions of sale of semiconductor products. Testing and other quality control techniques are used to the extent TI deems necessary to support this warranty. Except where mandated by applicable law, testing of all parameters of each component is not necessarily performed.

TI assumes no liability for applications assistance or the design of Buyers' products. Buyers are responsible for their products and applications using TI components. To minimize the risks associated with Buyers' products and applications, Buyers should provide adequate design and operating safeguards.

TI does not warrant or represent that any license, either express or implied, is granted under any patent right, copyright, mask work right, or other intellectual property right relating to any combination, machine, or process in which TI components or services are used. Information published by TI regarding third-party products or services does not constitute a license to use such products or services or a warranty or endorsement thereof. Use of such information may require a license from a third party under the patents or other intellectual property of the third party, or a license from TI under the patents or other intellectual property of TI.

Reproduction of significant portions of TI information in TI data books or data sheets is permissible only if reproduction is without alteration and is accompanied by all associated warranties, conditions, limitations, and notices. TI is not responsible or liable for such altered documentation. Information of third parties may be subject to additional restrictions.

Resale of TI components or services with statements different from or beyond the parameters stated by TI for that component or service voids all express and any implied warranties for the associated TI component or service and is an unfair and deceptive business practice. TI is not responsible or liable for any such statements.

Buyer acknowledges and agrees that it is solely responsible for compliance with all legal, regulatory and safety-related requirements concerning its products, and any use of TI components in its applications, notwithstanding any applications-related information or support that may be provided by TI. Buyer represents and agrees that it has all the necessary expertise to create and implement safeguards which anticipate dangerous consequences of failures, monitor failures and their consequences, lessen the likelihood of failures that might cause harm and take appropriate remedial actions. Buyer will fully indemnify TI and its representatives against any damages arising out of the use of any TI components in safety-critical applications.

In some cases, TI components may be promoted specifically to facilitate safety-related applications. With such components, TI's goal is to help enable customers to design and create their own end-product solutions that meet applicable functional safety standards and requirements. Nonetheless, such components are subject to these terms.

No TI components are authorized for use in FDA Class III (or similar life-critical medical equipment) unless authorized officers of the parties have executed a special agreement specifically governing such use.

Only those TI components which TI has specifically designated as military grade or "enhanced plastic" are designed and intended for use in military/aerospace applications or environments. Buyer acknowledges and agrees that any military or aerospace use of TI components which have **not** been so designated is solely at the Buyer's risk, and that Buyer is solely responsible for compliance with all legal and regulatory requirements in connection with such use.

TI has specifically designated certain components as meeting ISO/TS16949 requirements, mainly for automotive use. In any case of use of non-designated products, TI will not be responsible for any failure to meet ISO/TS16949.

Products

Audio	www.ti.com/audio
Amplifiers	amplifier.ti.com
Data Converters	dataconverter.ti.com
DLP® Products	www.dlp.com
DSP	dsp.ti.com
Clocks and Timers	www.ti.com/clocks
Interface	interface.ti.com
Logic	logic.ti.com
Power Mgmt	power.ti.com
Microcontrollers	microcontroller.ti.com
RFID	www.ti-rfid.com
OMAP Applications Processors	www.ti.com/omap
Wireless Connectivity	www.ti.com/wirelessconnectivity

Applications

Automotive and Transportation	www.ti.com/automotive
Communications and Telecom	www.ti.com/communications
Computers and Peripherals	www.ti.com/computers
Consumer Electronics	www.ti.com/consumer-apps
Energy and Lighting	www.ti.com/energy
Industrial	www.ti.com/industrial
Medical	www.ti.com/medical
Security	www.ti.com/security
Space, Avionics and Defense	www.ti.com/space-avionics-defense
Video and Imaging	www.ti.com/video

TI E2E Community

e2e.ti.com