

3.3-V CAN TRANSCEIVERS

 Check for Samples: [SN65HVD230](#), [SN65HVD231](#), [SN65HVD232](#)

FEATURES

- Operates With a 3.3-V Supply
- Low Power Replacement for the PCA82C250 Footprint
- Bus/Pin ESD Protection Exceeds 16 kV HBM
- High Input Impedance Allows for 120 Nodes on a Bus
- Controlled Driver Output Transition Times for Improved Signal Quality on the SN65HVD230 and SN65HVD231
- Unpowered Node Does Not Disturb the Bus
- Compatible With the Requirements of the ISO 11898 Standard
- Low-Current SN65HVD230 Standby Mode 370 μ A Typical
- Low-Current SN65HVD231 Sleep Mode 40 nA Typical
- Designed for Signaling Rates⁽¹⁾ up to 1 Megabit/Second (Mbps)
- Thermal Shutdown Protection
- Open-Circuit Fail-Safe Design
- Glitch-Free Power-Up and Power-Down Protection for Hot-Plugging Applications

⁽¹⁾ The signaling rate of a line is the number of voltage transitions that are made per second expressed in the units bps (bits per second).

APPLICATIONS

- Motor Control
- Industrial Automation
- Basestation Control and Status
- Robotics
- Automotive
- UPS Control

SN65HVD230D (Marked as VP230)
SN65HVD231D (Marked as VP231)

(TOP VIEW)

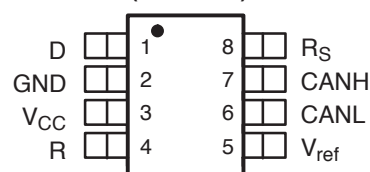

SN65HVD232D (Marked as VP232)

(TOP VIEW)

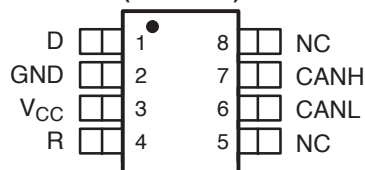

NC – No internal connection

LOGIC DIAGRAM (POSITIVE LOGIC)

SN65HVD230, SN65HVD231
Logic Diagram (Positive Logic)

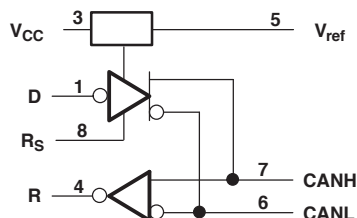

SN65HVD232
Logic Diagram (Positive Logic)

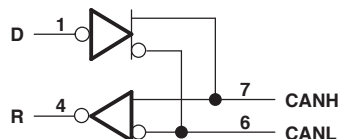

Please be aware that an important notice concerning availability, standard warranty, and use in critical applications of Texas Instruments semiconductor products and disclaimers thereto appears at the end of this data sheet.

TMS320Lx240x is a trademark of Texas Instruments.



These devices have limited built-in ESD protection. The leads should be shorted together or the device placed in conductive foam during storage or handling to prevent electrostatic damage to the MOS gates.

DESCRIPTION

The SN65HVD230, SN65HVD231, and SN65HVD232 controller area network (CAN) transceivers are designed for use with the Texas Instruments TMS320Lx240x™ ; 3.3-V DSPs with CAN controllers, or with equivalent devices. They are intended for use in applications employing the CAN serial communication physical layer in accordance with the ISO 11898 standard. Each CAN transceiver is designed to provide differential transmit capability to the bus and differential receive capability to a CAN controller at speeds up to 1 Mbps.

Designed for operation in especially-harsh environments, these devices feature cross-wire protection, loss-of-ground and overvoltage protection, overtemperature protection, as well as wide common-mode range.

The transceiver interfaces the single-ended CAN controller with the differential CAN bus found in industrial, building automation, and automotive applications. It operates over a -2-V to 7-V common-mode range on the bus, and it can withstand common-mode transients of ± 25 V.

On the SN65HVD230 and SN65HVD231, pin 8 provides three different modes of operation: high-speed, slope control, and low-power modes. The high-speed mode of operation is selected by connecting pin 8 to ground, allowing the transmitter output transistors to switch on and off as fast as possible with no limitation on the rise and fall slopes. The rise and fall slopes can be adjusted by connecting a resistor to ground at pin 8, since the slope is proportional to the pin's output current. This slope control is implemented with external resistor values of 10 k Ω , to achieve a 15-V/ μ s slew rate, to 100 k Ω , to achieve a 2-V/ μ s slew rate. See the *Application Information* section of this data sheet.

The circuit of the SN65HVD230 enters a low-current standby mode during which the driver is switched off and the receiver remains active if a high logic level is applied to pin 8. The DSP controller reverses this low-current standby mode when a dominant state (bus differential voltage > 900 mV typical) occurs on the bus.

The unique difference between the SN65HVD230 and the SN65HVD231 is that both the driver and the receiver are switched off in the SN65HVD231 when a high logic level is applied to pin 8 and remain in this sleep mode until the circuit is reactivated by a low logic level on pin 8.

The V_{ref} pin 5 on the SN65HVD230 and SN65HVD231 is available as a $V_{CC}/2$ voltage reference.

The SN65HVD232 is a basic CAN transceiver with no added options; pins 5 and 8 are NC, no connection.

Table 1. AVAILABLE OPTIONS⁽¹⁾

PART NUMBER	LOW POWER MODE	INTEGRATED SLOPE CONTROL	V_{ref} PIN	T_A	MARKED AS:
SN65HVD230	Standby mode	Yes	Yes	40°C to 85°C	VP230
SN65HVD231	Sleep mode	Yes	Yes		VP231
SN65HVD232	No standby or sleep mode	No	No		VP232

(1) For the most current package and ordering information, see the Package Option Addendum at the end of this document, or see the TI web site at www.ti.com.

FUNCTION TABLES

DRIVER (SN65HVD230, SN65HVD231) ⁽¹⁾				
INPUT D	R_S	OUTPUTS		BUS STATE
		CANH	CANL	
L	$V_{(RS)} < 1.2$ V	H	L	Dominant
H		Z	Z	Recessive
Open	X	Z	Z	Recessive
X	$V_{(RS)} > 0.75$ V_{CC}	Z	Z	Recessive

(1) H = high level; L = low level; X = irrelevant; ? = indeterminate; Z = high impedance

Table 2.

DRIVER (SN65HVD232) ⁽¹⁾			
INPUT D	OUTPUTS		BUS STATE
	CANH	CANL	
L	H	L	Dominant
H	Z	Z	Recessive
Open	Z	Z	Recessive

(1) H = high level; L = low level; Z = high impedance

Table 3.

RECEIVER (SN65HVD230) ⁽¹⁾		
DIFFERENTIAL INPUTS	R _S	OUTPUT R
V _{ID} ≥ 0.9 V	X	L
0.5 V < V _{ID} < 0.9 V	X	?
V _{ID} ≤ 0.5 V	X	H
Open	X	H

(1) H = high level; L = low level; X = irrelevant; ? = indeterminate

Table 4.

RECEIVER (SN65HVD231) ⁽¹⁾		
DIFFERENTIAL INPUTS	R _S	OUTPUT R
V _{ID} ≥ 0.9 V	V _(RS) < 1.2 V	L
0.5 V < V _{ID} < 0.9 V		?
V _{ID} ≤ 0.5 V		H
X	V _(RS) > 0.75 V _{CC}	H
X	1.2 V < V _(RS) < 0.75 V _{CC}	?
Open	X	H

(1) H = high level; L = low level; X = irrelevant; ? = indeterminate

Table 5.

RECEIVER (SN65HVD232) ⁽¹⁾	
DIFFERENTIAL INPUTS	OUTPUT R
V _{ID} ≥ 0.9 V	L
0.5 V < V _{ID} < 0.9 V	?
V _{ID} ≤ 0.5 V	H
Open	H

(1) H = high level; L = low level; X = irrelevant; ? = indeterminate

Table 6.

TRANSCEIVER MODES (SN65HVD230, SN65HVD231)	
V _(RS)	OPERATING MODE
V _(RS) > 0.75 V _{CC}	Standby
10 kΩ to 100 kΩ to ground	Slope control
V _(RS) < 1 V	High speed (no slope control)

TERMINAL FUNCTIONS

TERMINAL		DESCRIPTION
NAME	NO.	
SN65HVD230, SN65HVD231		
CANL	6	Low bus output
CANH	7	High bus output
D	1	Driver input
GND	2	Ground
R	4	Receiver output
R _S	8	Standby/slope control
V _{CC}	3	Supply voltage
V _{ref}	5	Reference output
SN65HVD232		
CANL	6	Low bus output
CANH	7	High bus output
D	1	Driver input
GND	2	Ground
NC	5, 8	No connection
R	4	Receiver output
V _{CC}	3	Supply voltage

EQUIVALENT INPUT AND OUTPUT SCHEMATIC DIAGRAMS

CANH and CANL Inputs

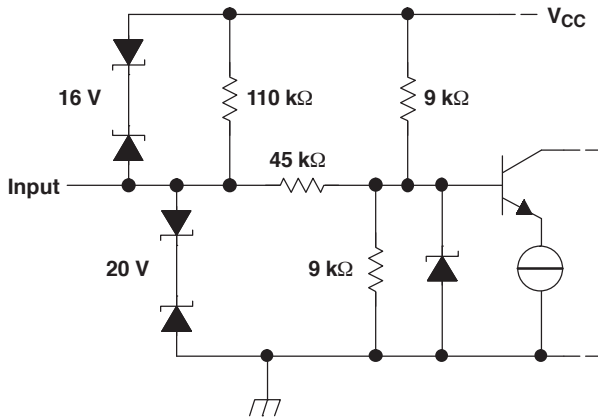

D Input

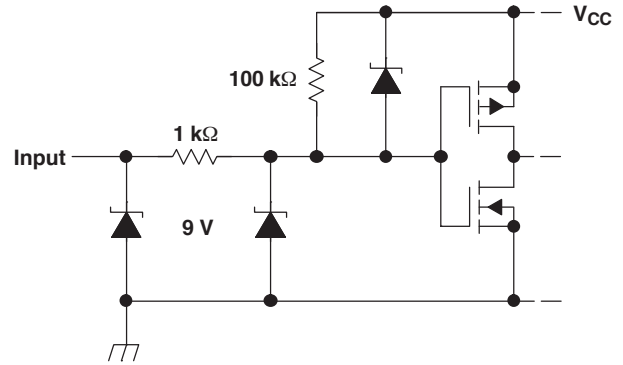

CANH and CANL Outputs

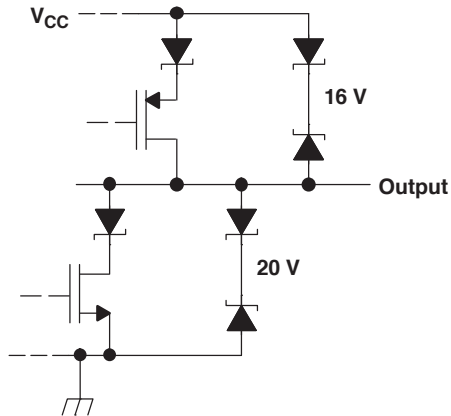

R Output

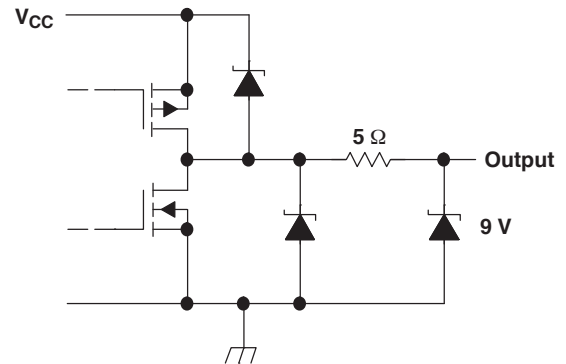

ABSOLUTE MAXIMUM RATINGS

over operating free-air temperature range (unless otherwise noted)⁽¹⁾ ⁽²⁾

			UNIT
Supply voltage range, V_{CC}			-0.3 V to 6 V
Voltage range at any bus terminal (CANH or CANL)			-4 V to 16 V
Voltage input range, transient pulse, CANH and CANL, through 100 Ω (see Figure 7)			-25 V to 25 V
Input voltage range, V_I (D or R)			-0.5 V to $V_{CC} + 0.5$ V
Receiver output current, I_O			± 11 mA
Electrostatic discharge	Human body model ⁽³⁾	CANH, CANL and GND	16 kV
		All Pins	4 kV
	Charged-device model ⁽⁴⁾	All pins	1 kV
Continuous total power dissipation			See the Thermal Information Table

- (1) Stresses beyond those listed under "absolute maximum ratings" may cause permanent damage to the device. These are stress ratings only, and functional operation of the device at these or any other conditions beyond those indicated under "recommended operating conditions" is not implied. Exposure to absolute-maximum-rated conditions for extended periods may affect device reliability.
- (2) All voltage values, except differential I/O bus voltages, are with respect to network ground terminal.
- (3) Tested in accordance with JEDEC Standard 22, Test Method A114-A.
- (4) Tested in accordance with JEDEC Standard 22, Test Method C101.

THERMAL INFORMATION

THERMAL METRIC ⁽¹⁾		SN65HVD230	SN65HVD231	SN65HVD232	UNITS
		D (8 Pins)	D (8 Pins)	D (8 Pins)	
θ_{JA}	Junction-to-ambient thermal resistance	76.8	101.5	101.5	°C/W
θ_{JCTop}	Junction-to-case (top) thermal resistance	33.4	43.3	43.3	
θ_{JB}	Junction-to-board thermal resistance	15.3	42.2	42.4	
Ψ_{JT}	Junction-to-top characterization parameter	1.4	4.8	4.8	
Ψ_{JB}	Junction-to-board characterization parameter	14.9	41.8	41.8	
θ_{JCbott}	Junction-to-case (bottom) thermal resistance	n/a	n/a	n/a	

- (1) For more information about traditional and new thermal metrics, see the *IC Package Thermal Metrics* application report, [SPRA953](#).

RECOMMENDED OPERATING CONDITIONS

		MIN	NOM	MAX	UNIT
Supply voltage, V_{CC}			3	3.6	V
Voltage at any bus terminal (common mode) V_{IC}		-2 ⁽¹⁾		7	V
Voltage at any bus terminal (separately) V_I		-2.5		7.5	V
High-level input voltage, V_{IH}	D, R		2		V
Low-level input voltage, V_{IL}	D, R			0.8	V
Differential input voltage, V_{ID} (see Figure 5)		-6		6	V
Input voltage, $V_{(RS)}$			0	V_{CC}	V
Input voltage for standby or sleep, $V_{(RS)}$			0.75 V_{CC}	V_{CC}	V
Wave-shaping resistance, R_s			0	100	k Ω
High-level output current, I_{OH}	Driver		-40		mA
	Receiver		-8		
Low-level output current, I_{OL}	Driver			48	mA
	Receiver			8	
Operating free-air temperature, T_A			-40	85	°C

- (1) The algebraic convention, in which the least positive (most negative) limit is designated as minimum is used in this data sheet.

DRIVER ELECTRICAL CHARACTERISTICS

over recommended operating conditions (unless otherwise noted)

PARAMETER			TEST CONDITIONS			MIN	TYP ⁽¹⁾	MAX	UNIT	
V _{OH}	Bus output voltage	Dominant	V _I = 0 V, See Figure 1 and Figure 3	CANH	2.45		V _{CC}	V		
				CANL	0.5	1.25				
V _{OL}		Recessive	V _I = 3 V, See Figure 1 and Figure 3	CANH		2.3				
				CANL		2.3				
V _{OD(D)}	Differential output voltage	Dominant	V _I = 0 V, See Figure 1		1.5	2	3	V		
			V _I = 0 V, See Figure 2		1.2	2	3			
V _{OD(R)}		Recessive	V _I = 3 V, See Figure 1		-120	0	12	mV		
			V _I = 3 V, No load		-0.5	-0.2	0.05	V		
I _{IH}	High-level input current		V _I = 2 V			-30		μA		
I _{IL}	Low-level input current		V _I = 0.8 V			-30		μA		
I _{OS}	Short-circuit output current		V _{CANH} = -2 V			-250	250	mA		
			V _{CANL} = 7 V			-250	250			
C _o	Output capacitance		See receiver							
I _{CC}	Supply current	Standby	SN65HVD230	V _(RS) = V _{CC}			370	600	μA	
		Sleep	SN65HVD231	V _(RS) = V _{CC} , D at V _{CC}			0.04	1		
		All devices	Dominant	V _I = 0 V, No load		Dominant		10	17	mA
			Recessive	V _I = V _{CC} , No load		Recessive		10	17	

(1) All typical values are at 25°C and with a 3.3-V supply.

DRIVER SWITCHING CHARACTERISTICS

over recommended operating conditions (unless otherwise noted)

PARAMETER			TEST CONDITIONS	MIN	TYP	MAX	UNIT
SN65HVD230 AND SN65HVD231							
t _{PLH}	Propagation delay time, low-to-high-level output	V _(RS) = 0 V	C _L = 50 pF, See Figure 4	35	85		ns
		R _S with 10 kΩ to ground		70	125		
		R _S with 100 kΩ to ground		500	870		
t _{PHL}	Propagation delay time, high-to-low-level output	V _(RS) = 0 V		70	120		ns
		R _S with 10 kΩ to ground		130	180		
		R _S with 100 kΩ to ground		870	1200		
t _{sk(p)}	Pulse skew (t _{PHL} - t _{PLH})	V _(RS) = 0 V		35			ns
		R _S with 10 kΩ to ground		60			
		R _S with 100 kΩ to ground		370			
t _r	Differential output signal rise time	V _(RS) = 0 V	25	50	100	ns	
t _f	Differential output signal fall time		40	55	80	ns	
t _r	Differential output signal rise time	R _S with 10 kΩ to ground	80	120	160	ns	
t _f	Differential output signal fall time		80	125	150	ns	
t _r	Differential output signal rise time	R _S with 100 kΩ to ground	600	800	1200	ns	
t _f	Differential output signal fall time		600	825	1000	ns	
SN65HVD232							
t _{PLH}	Propagation delay time, low-to-high-level output	C _L = 50 pF, See Figure 4	35	85		ns	
t _{PHL}	Propagation delay time, high-to-low-level output		70	120			
t _{sk(p)}	Pulse skew (t _{PHL} - t _{PLH})		35				
t _r	Differential output signal rise time		25	50	100		
t _f	Differential output signal fall time		40	55	80		

RECEIVER ELECTRICAL CHARACTERISTICS

over recommended operating conditions (unless otherwise noted)

PARAMETER		TEST CONDITIONS	MIN	TYP ⁽¹⁾	MAX	UNIT	
V _{IT+}	Positive-going input threshold voltage	See Table 7		750	900	mV	
V _{IT-}	Negative-going input threshold voltage		500	650		mV	
V _{hys}	Hysteresis voltage (V _{IT+} - V _{IT-})			100			
V _{OH}	High-level output voltage	-6 V ≤ V _{ID} ≤ 500 mV, I _O = -8 mA, See Figure 5	2.4			V	
V _{OL}	Low-level output voltage	900 mV ≤ V _{ID} ≤ 6 V, I _O = 8 mA, See Figure 5			0.4		
I _I	Bus input current	V _{IH} = 7 V	Other input at 0 V, D = 3 V		100	250	μA
		V _{IH} = 7 V, V _{CC} = 0 V		100		350	
		V _{IH} = -2 V		-200		-30	μA
		V _{IH} = -2 V, V _{CC} = 0 V		-100		-20	
C _i	CANH, CANL input capacitance	Pin-to-ground, V _I = 0.4 sin(4E6πt) + 0.5 V V _(D) = 3 V,		32		pF	
C _{diff}	Differential input capacitance	Pin-to-pin, V _I = 0.4 sin(4E6πt) + 0.5 V V _(D) = 3 V,		16		pF	
R _{diff}	Differential input resistance	Pin-to-pin, V _(D) = 3 V	40	70	100	kΩ	
R _I	CANH, CANL input resistance		20	35	50	kΩ	
I _{CC}	Supply current	See driver					

(1) All typical values are at 25°C and with a 3.3-V supply.

RECEIVER SWITCHING CHARACTERISTICS

over recommended operating conditions (unless otherwise noted)

PARAMETER		TEST CONDITIONS	MIN	TYP	MAX	UNIT
t _{PLH}	Propagation delay time, low-to-high-level output	See Figure 6		35	50	ns
t _{PHL}	Propagation delay time, high-to-low-level output		35	50		ns
t _{sk(p)}	Pulse skew (t _{PHL} - t _{PLH})				10	ns
t _r	Output signal rise time	See Figure 6		1.5		ns
t _f	Output signal fall time			1.5		ns

DEVICE SWITCHING CHARACTERISTICS

over recommended operating conditions (unless otherwise noted)

PARAMETER		TEST CONDITIONS	MIN	TYP	MAX	UNIT
t _(LOOP1)	Total loop delay, driver input to receiver output, recessive to dominant	V _(RS) = 0 V, See Figure 9		70	115	ns
		R _S with 10 kΩ to ground, See Figure 9		105	175	
		R _S with 100 kΩ to ground, See Figure 9		535	920	
t _(LOOP2)	Total loop delay, driver input to receiver output, dominant to recessive	V _(RS) = 0 V, See Figure 9		100	135	ns
		R _S with 10 kΩ to ground, See Figure 9		155	185	
		R _S with 100 kΩ to ground, See Figure 9		830	990	

DEVICE CONTROL-PIN CHARACTERISTICS

over recommended operating conditions (unless otherwise noted)

PARAMETER		TEST CONDITIONS	MIN	TYP ⁽¹⁾	MAX	UNIT
$t_{(WAKE)}$	SN65HVD230 wake-up time from standby mode with R_S	See Figure 8		0.55	1.5	μs
	SN65HVD231 wake-up time from sleep mode with R_S			3	5	μs
V_{ref}	Reference output voltage	$-5 \mu A < I_{(Vref)} < 5 \mu A$	$0.45 V_{CC}$		$0.55 V_{CC}$	V
		$-50 \mu A < I_{(Vref)} < 50 \mu A$	$0.4 V_{CC}$		$0.6 V_{CC}$	
$I_{(RS)}$	Input current for high-speed	$V_{(RS)} < 1 V$	-450		0	μA

(1) All typical values are at 25°C and with a 3.3-V supply.

PARAMETER MEASUREMENT INFORMATION

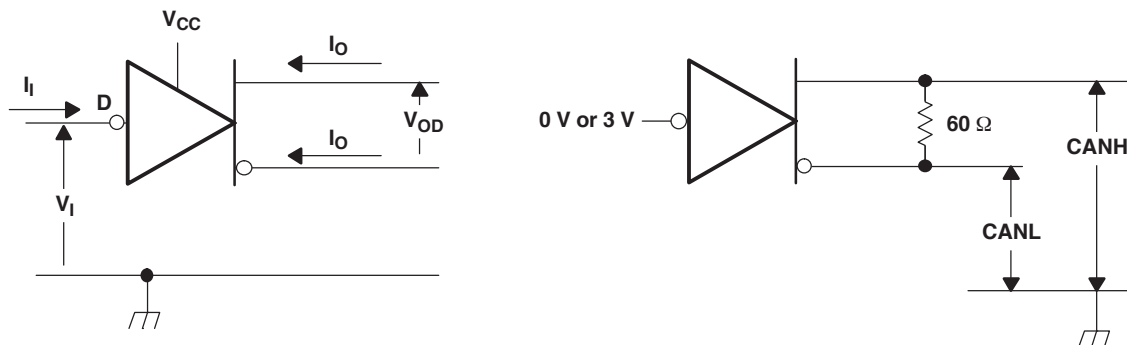

Figure 1. Driver Voltage and Current Definitions

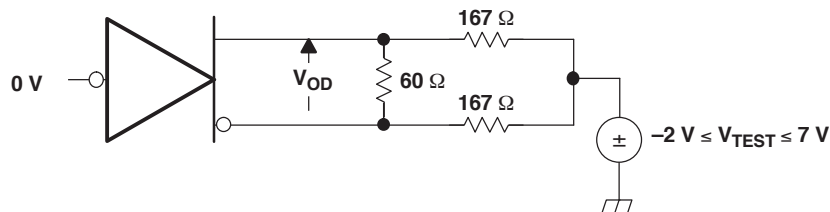

Figure 2. Driver V_{OD}

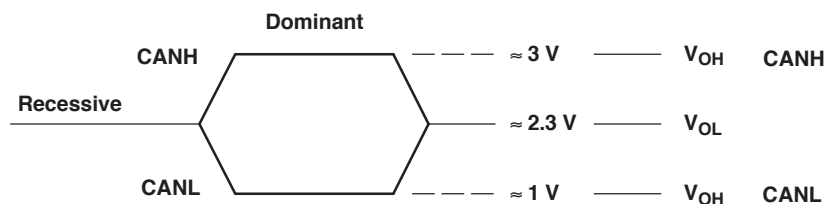
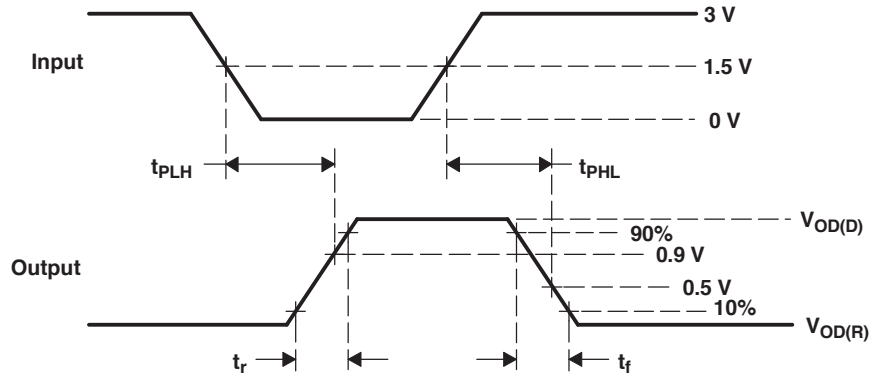
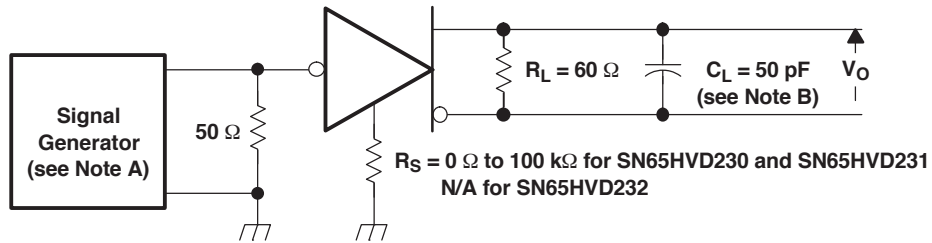

Figure 3. Driver Output Voltage Definitions

PARAMETER MEASUREMENT INFORMATION (continued)



- A. The input pulse is supplied by a generator having the following characteristics: PRR \leq 500 kHz, 50% duty cycle, $t_r \leq 6$ ns, $t_f \leq 6$ ns, $Z_o = 50\ \Omega$.
- B. C_L includes probe and jig capacitance.

Figure 4. Driver Test Circuit and Voltage Waveforms

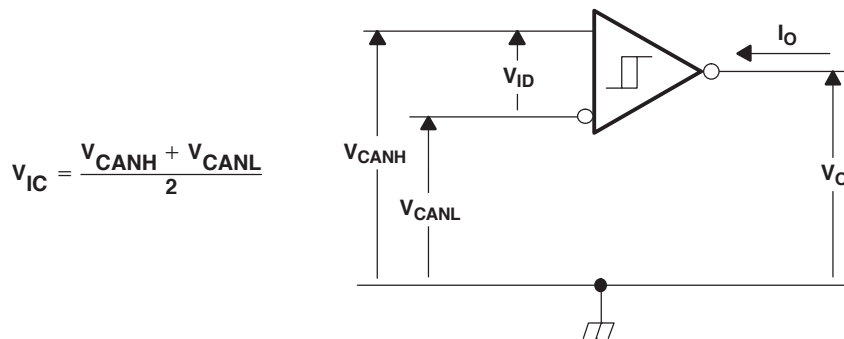
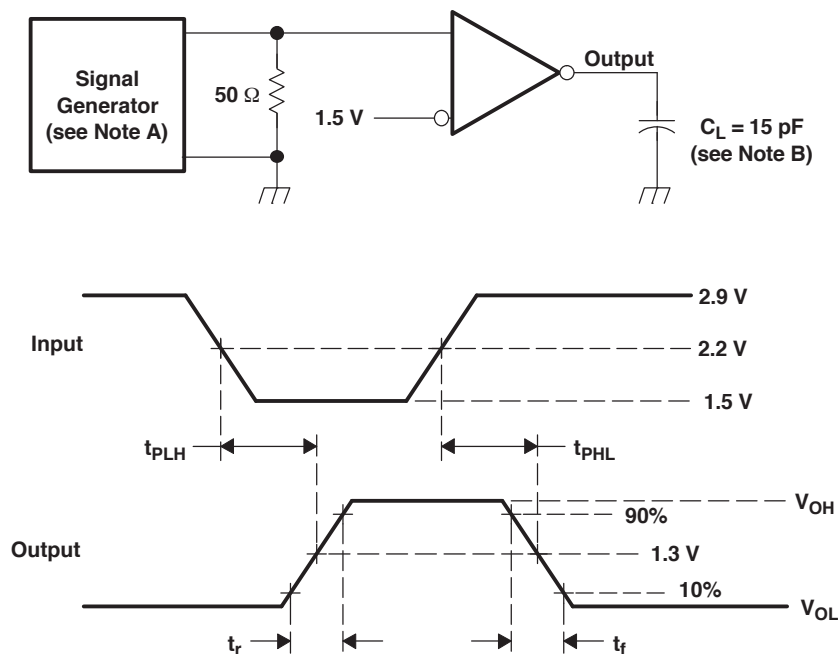

Figure 5. Receiver Voltage and Current Definitions

PARAMETER MEASUREMENT INFORMATION (continued)



- A. The input pulse is supplied by a generator having the following characteristics: PRR $\leq 500 \text{ kHz}$, 50% duty cycle, $t_r \leq 6 \text{ ns}$, $t_f \leq 6 \text{ ns}$, $Z_o = 50 \text{ } \Omega$.
- B. C_L includes probe and jig capacitance.

Figure 6. Receiver Test Circuit and Voltage Waveforms

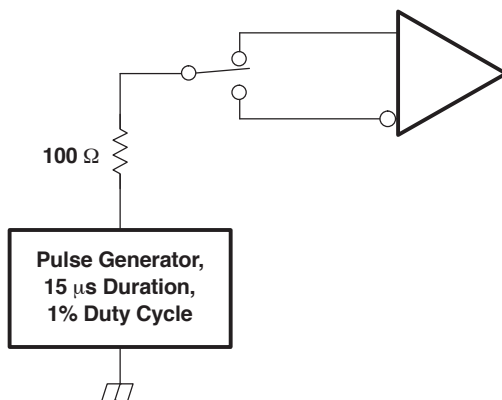

Figure 7. Overvoltage Protection

PARAMETER MEASUREMENT INFORMATION (continued)
Table 7. Receiver Characteristics Over Common Mode With $V_{(Rs)} = 1.2\text{ V}$

V_{IC}	V_{ID}	V_{CANH}	V_{CANL}	R OUTPUT	
-2 V	900 mV	-1.55 V	-2.45 V	L	V_{OL}
7 V	900 mV	8.45 V	6.55 V	L	
1 V	6 V	4 V	-2 V	L	
4 V	6 V	7 V	1 V	L	
-2 V	500 mV	-1.75 V	-2.25 V	H	V_{OH}
7 V	500 mV	7.25 V	6.75 V	H	
1 V	-6 V	-2 V	4 V	H	
4 V	-6 V	1 V	7 V	H	
X	X	Open	Open	H	

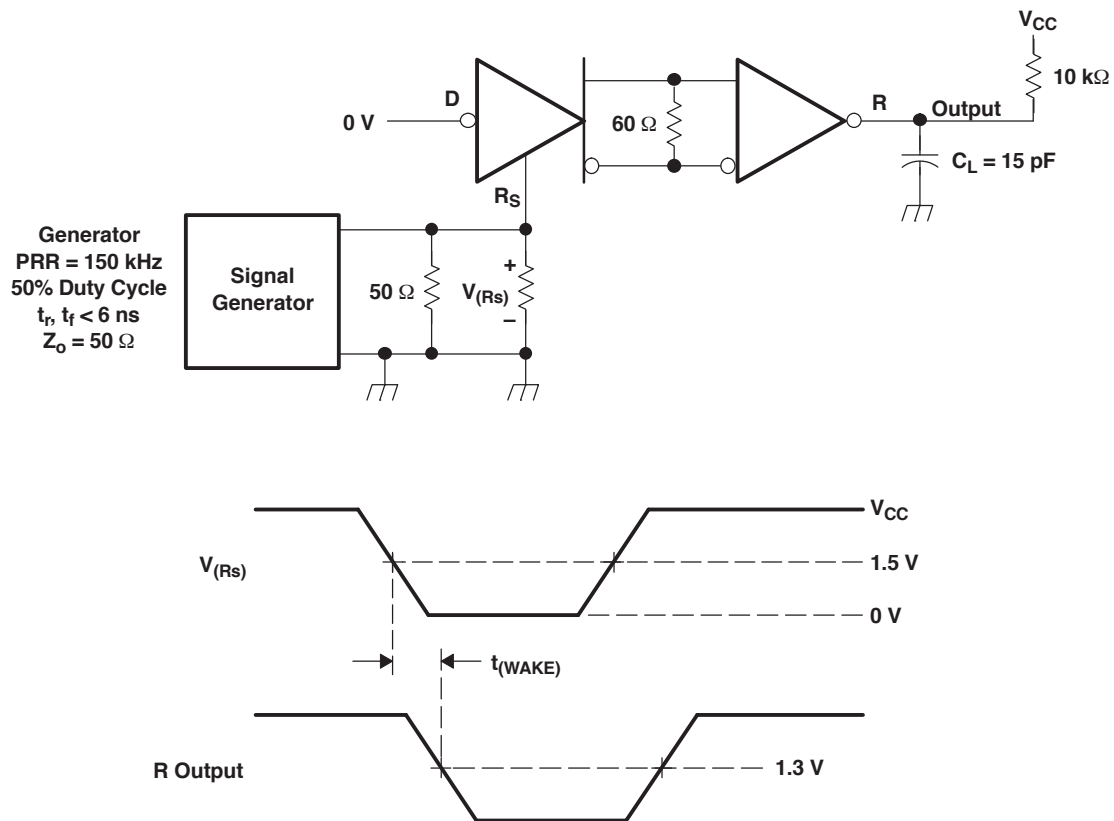
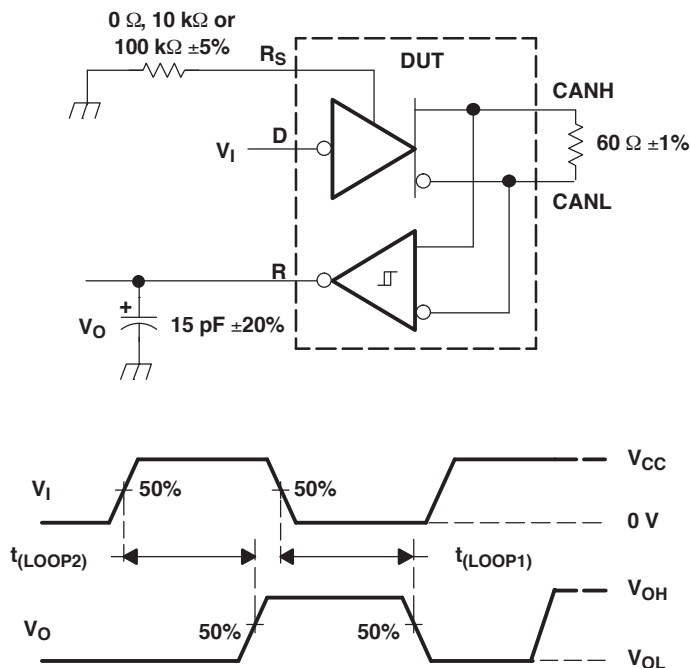

Figure 8. $t_{(WAKE)}$ Test Circuit and Voltage Waveforms



- A. All V_I input pulses are supplied by a generator having the following characteristics: t_r or $t_f \leq 6$ ns, Pulse Repetition Rate (PRR) = 125 kHz, 50% duty cycle.

Figure 9. $t_{(LOOP)}$ Test Circuit and Voltage Waveforms

TYPICAL CHARACTERISTICS

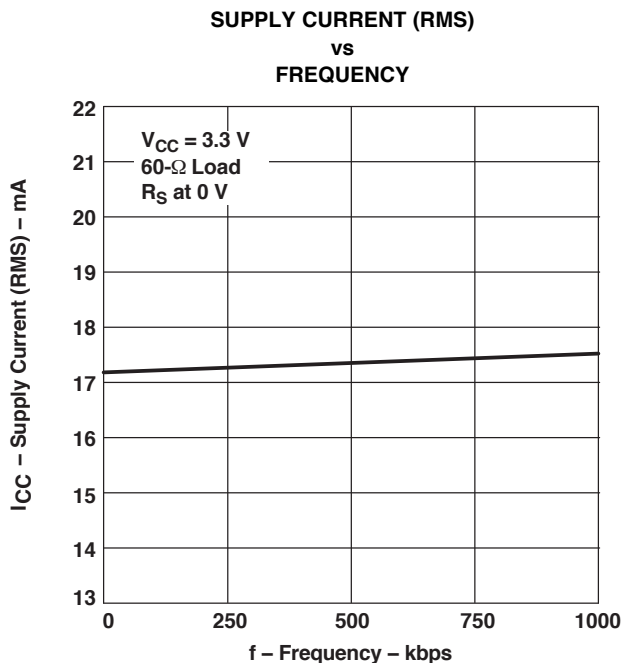

Figure 10.

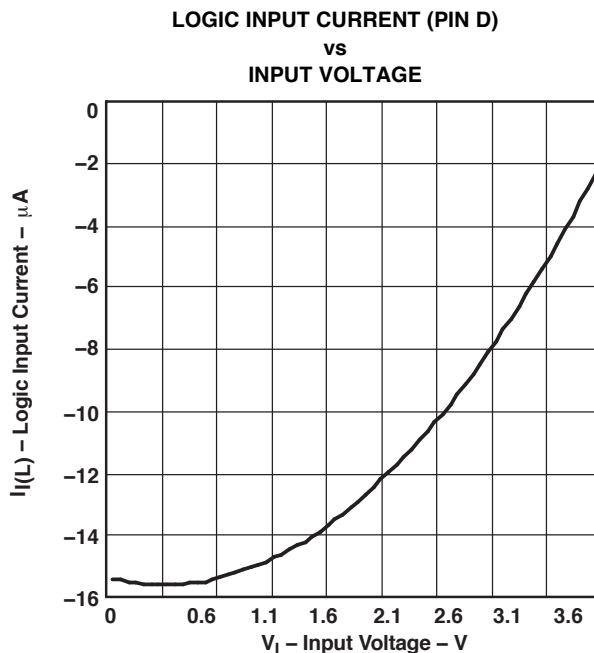

Figure 11.

TYPICAL CHARACTERISTICS (continued)

**BUS INPUT CURRENT
 vs
 BUS INPUT VOLTAGE**

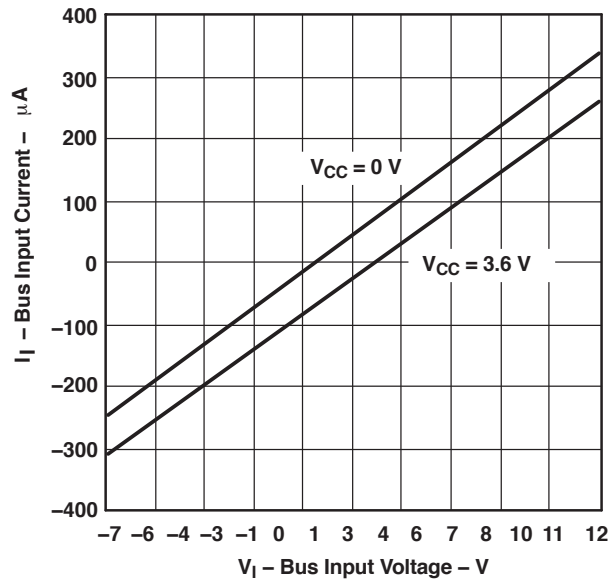

Figure 12.

**DRIVER LOW-LEVEL OUTPUT CURRENT
 vs
 LOW-LEVEL OUTPUT VOLTAGE**

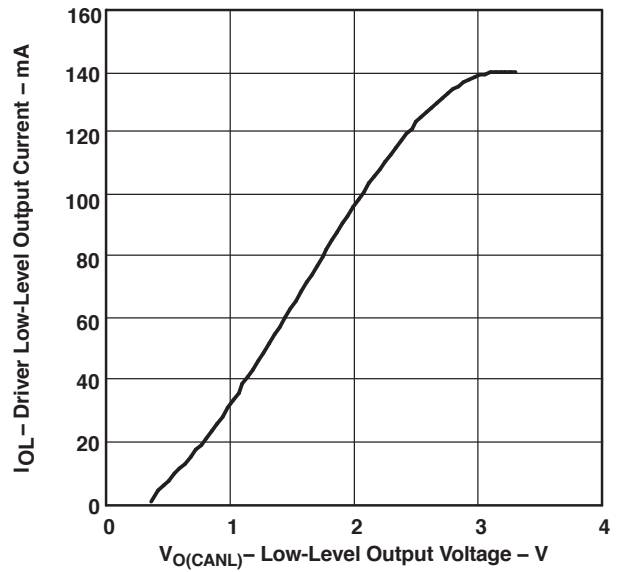

Figure 13.

**DRIVER HIGH-LEVEL OUTPUT CURRENT
 vs
 HIGH-LEVEL OUTPUT VOLTAGE**

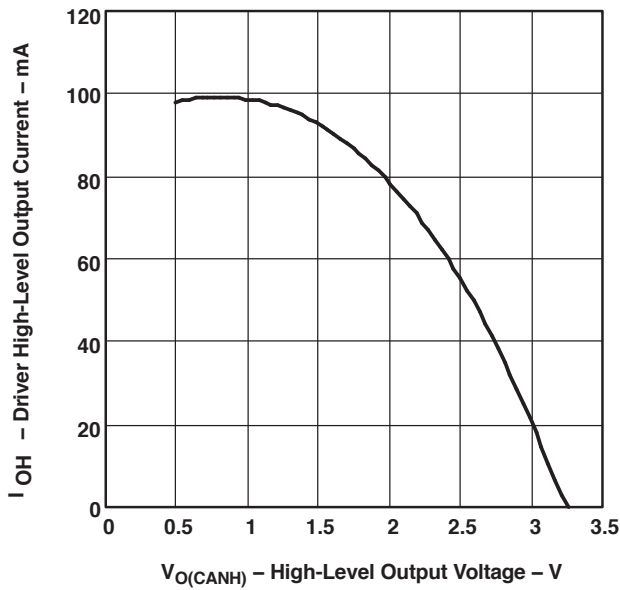

Figure 14.

**DOMINANT VOLTAGE (V_{OD})
 vs
 FREE-AIR TEMPERATURE**

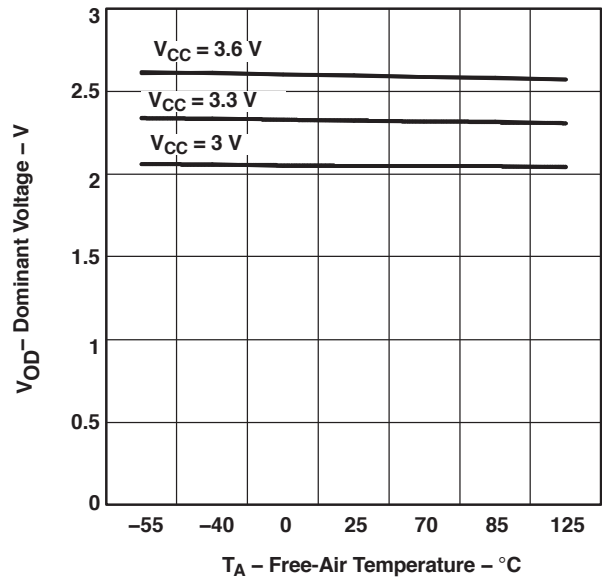

Figure 15.

TYPICAL CHARACTERISTICS (continued)

RECEIVER LOW-TO-HIGH PROPAGATION DELAY TIME vs FREE-AIR TEMPERATURE

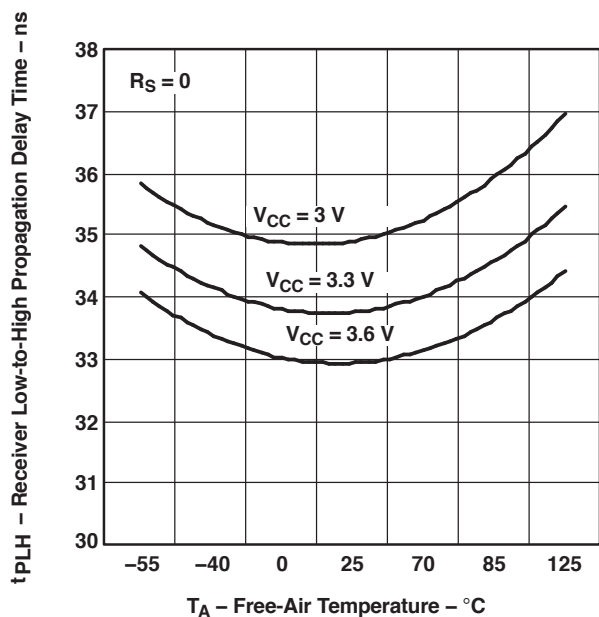

Figure 16.

RECEIVER HIGH-TO-LOW PROPAGATION DELAY TIME vs FREE-AIR TEMPERATURE

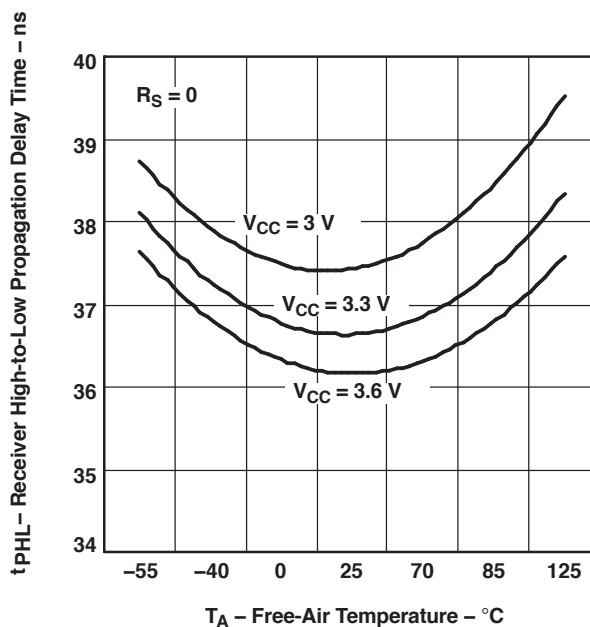

Figure 17.

DRIVER LOW-TO-HIGH PROPAGATION DELAY TIME vs FREE-AIR TEMPERATURE

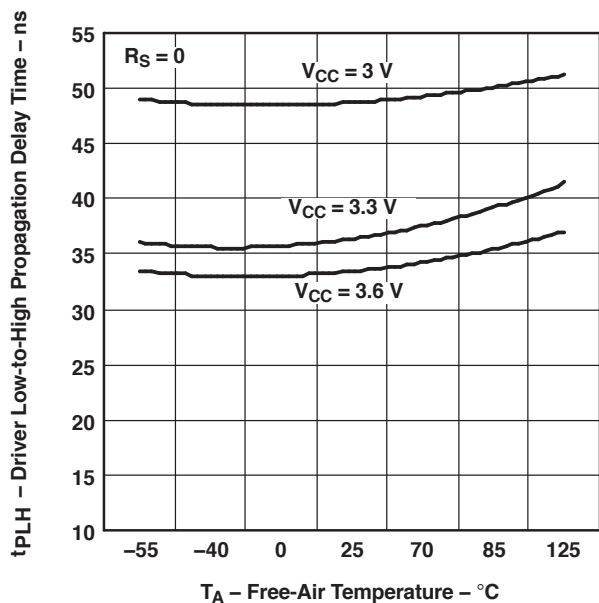

Figure 18.

DRIVER HIGH-TO-LOW PROPAGATION DELAY TIME vs FREE-AIR TEMPERATURE

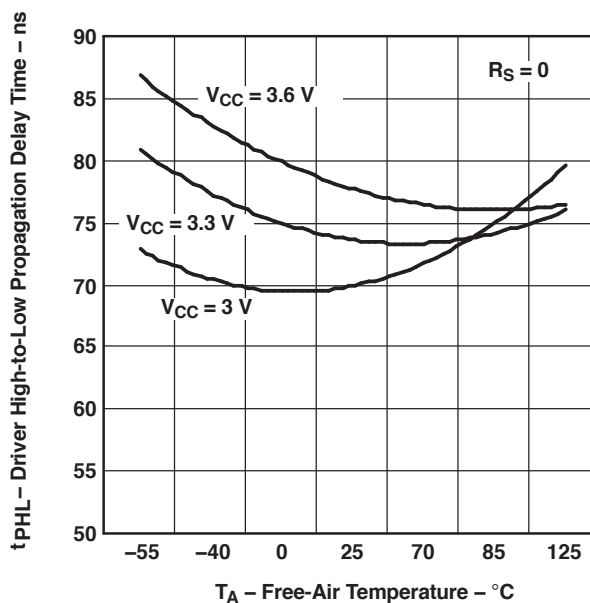

Figure 19.

TYPICAL CHARACTERISTICS (continued)

**DRIVER LOW-TO-HIGH PROPAGATION DELAY TIME
 vs
 FREE-AIR TEMPERATURE**

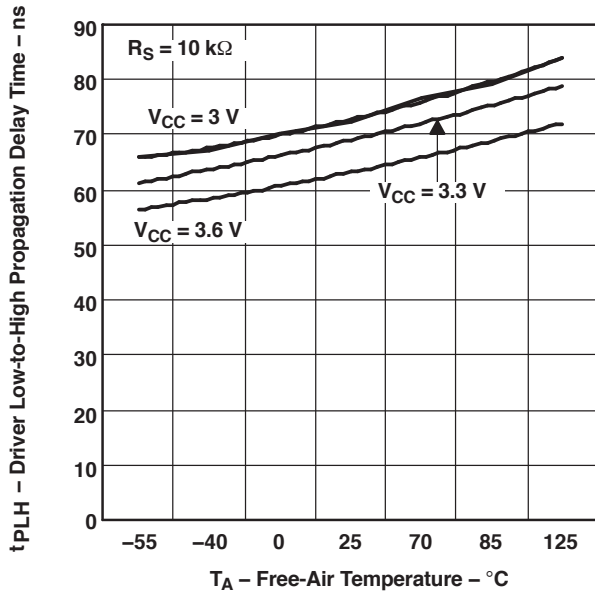

Figure 20.

**DRIVER HIGH-TO-LOW PROPAGATION DELAY TIME
 vs
 FREE-AIR TEMPERATURE**

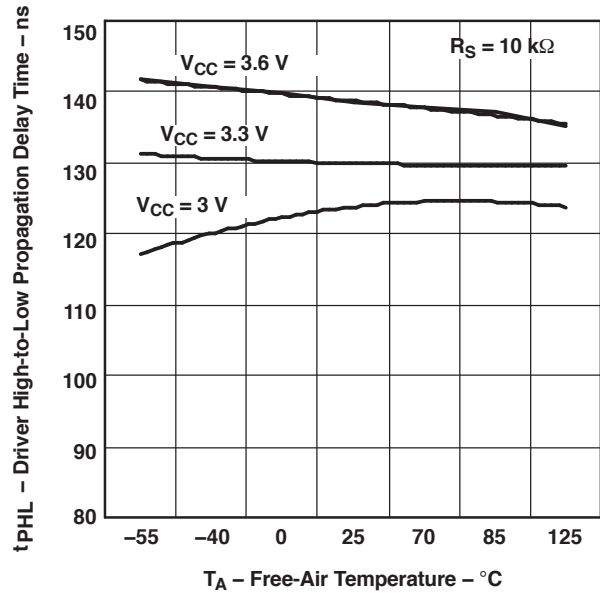

Figure 21.

**DRIVER LOW-TO-HIGH PROPAGATION DELAY TIME
 vs
 FREE-AIR TEMPERATURE**

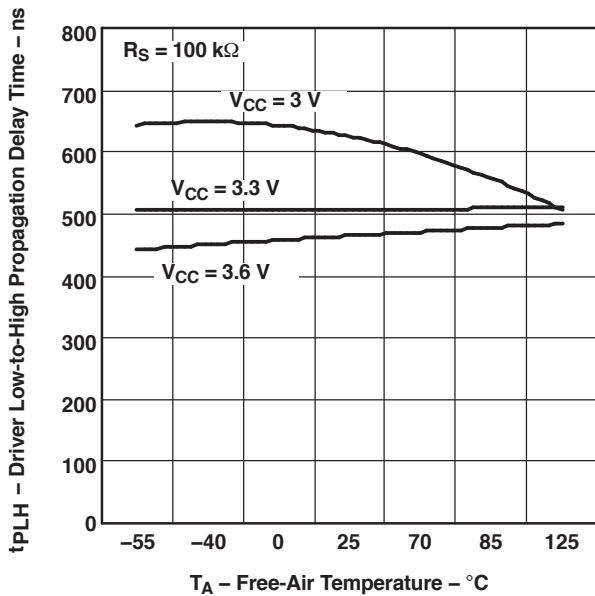

Figure 22.

**DRIVER HIGH-TO-LOW PROPAGATION DELAY TIME
 vs
 FREE-AIR TEMPERATURE**

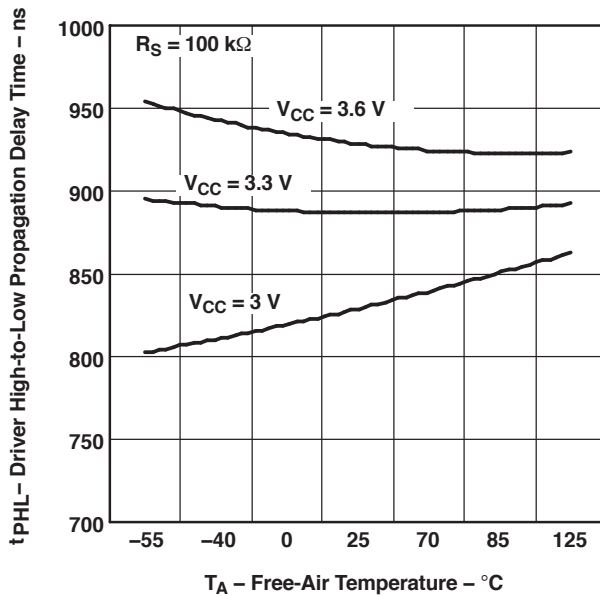

Figure 23.

TYPICAL CHARACTERISTICS (continued)

**DRIVER OUTPUT CURRENT
vs
SUPPLY VOLTAGE**

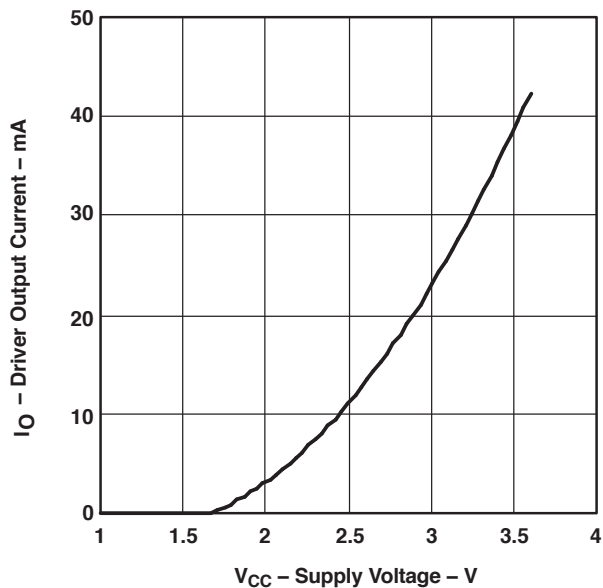

Figure 24.

**DIFFERENTIAL DRIVER OUTPUT FALL TIME
vs
SOURCE RESISTANCE (R_s)**

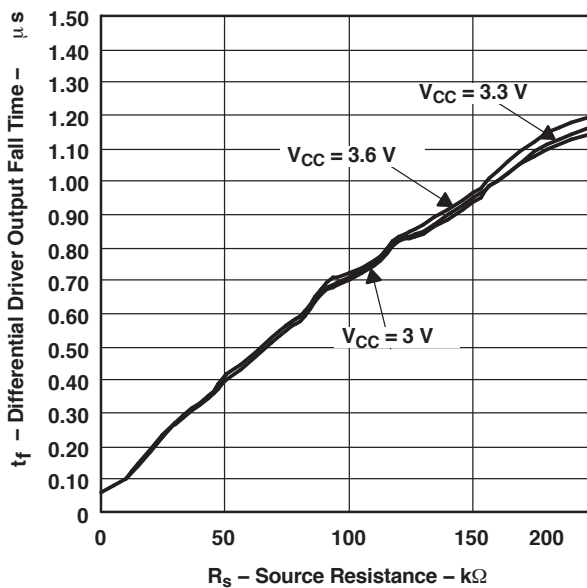

Figure 25.

**REFERENCE VOLTAGE
vs
REFERENCE CURRENT**

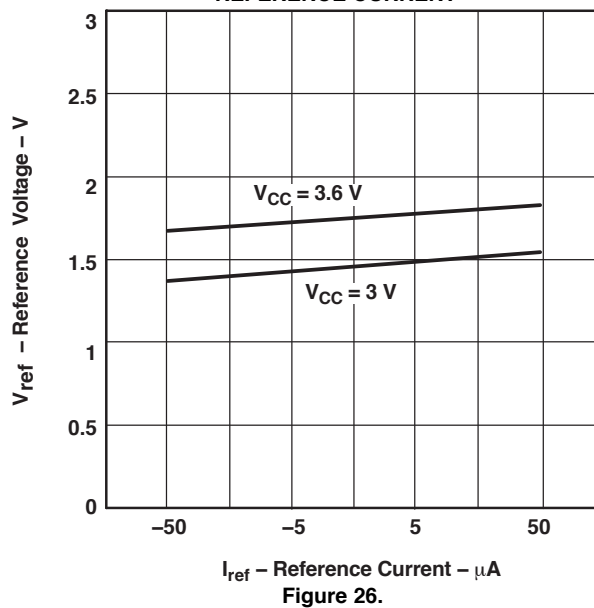

Figure 26.

APPLICATION INFORMATION

This application provides information concerning the implementation of the physical medium attachment layer in a CAN network according to the ISO 11898 standard. It presents a typical application circuit and test results, as well as discussions on slope control, total loop delay, and interoperability in 5-V systems.

INTRODUCTION

ISO 11898 is the international standard for high-speed serial communication using the controller area network (CAN) bus protocol. It supports multimaster operation, real-time control, programmable data rates up to 1 Mbps, and powerful redundant error checking procedures that provide reliable data transmission. It is suited for networking *intelligent* devices as well as sensors and actuators within the rugged electrical environment of a machine chassis or factory floor. The SN65HVD230 family of 3.3-V CAN transceivers implement the lowest layers of the ISO/OSI reference model. This is the interface with the physical signaling output of the CAN controller of the Texas Instruments TMS320Lx240x 3.3-V DSPs, as illustrated in [Figure 27](#).

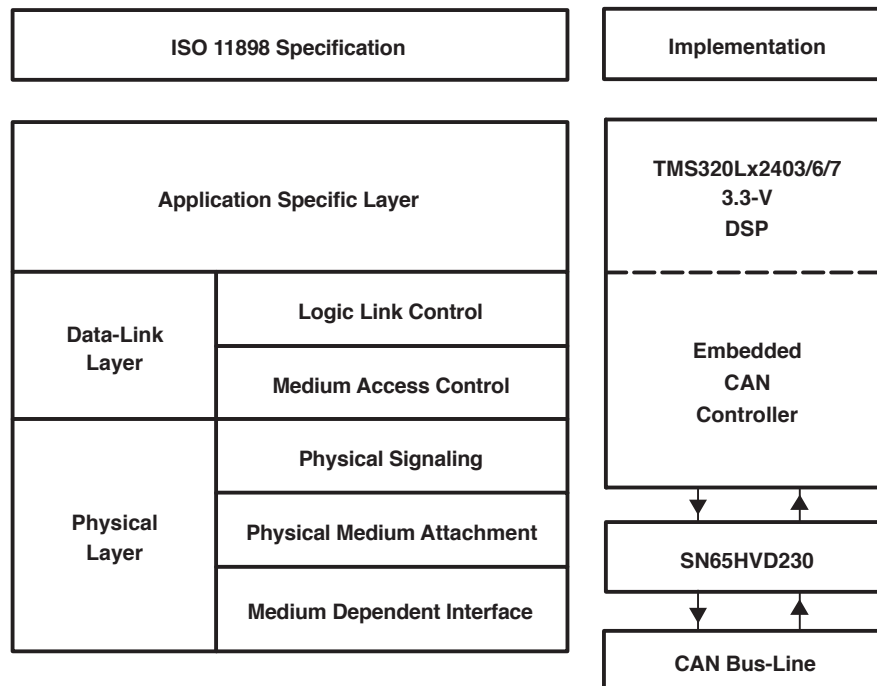

Figure 27. The Layered ISO 11898 Standard Architecture

The SN65HVD230 family of CAN transceivers are compatible with the ISO 11898 standard; this ensures interoperability with other standard-compliant products.

APPLICATION OF THE SN65HVD230

[Figure 28](#) illustrates a typical application of the SN65HVD230 family. The output of a DSP's CAN controller is connected to the serial driver input, pin D, and receiver serial output, pin R, of the transceiver. The transceiver is then attached to the differential bus lines at pins CANH and CANL. Typically, the bus is a twisted pair of wires with a characteristic impedance of 120 Ω , in the standard half-duplex multipoint topology of [Figure 29](#). Each end of the bus is terminated with 120- Ω resistors in compliance with the standard to minimize signal reflections on the bus.

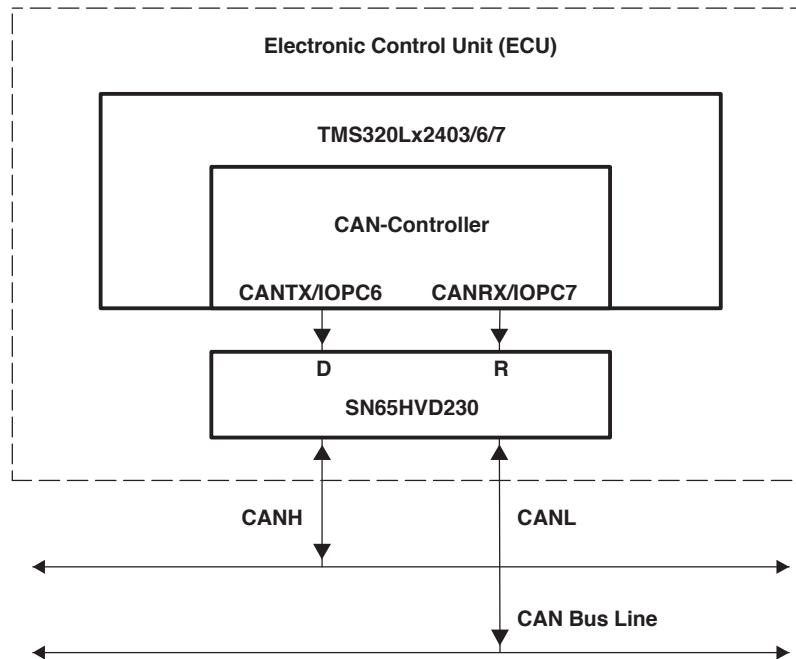

Figure 28. Details of a Typical CAN Node

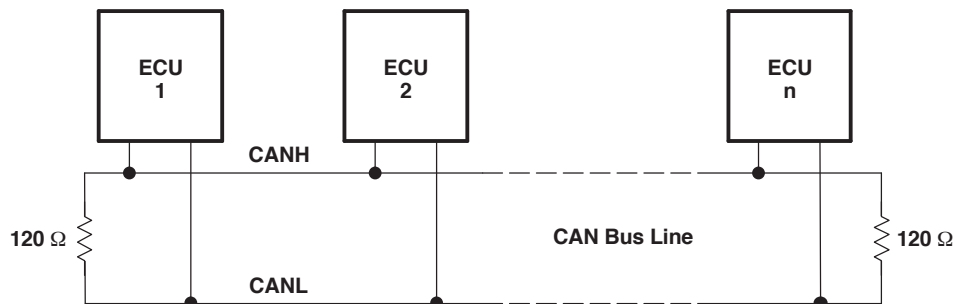

Figure 29. Typical CAN Network

The SN65HVD230/231/232 3.3-V CAN transceivers provide the interface between the 3.3-V TMS320Lx2403/6/7 CAN DSPs and the differential bus line, and are designed to transmit data at signaling rates up to 1 Mbps as defined by the ISO 11898 standard.

FEATURES of the SN65HVD230, SN65HVD231, and SN65HVD232

The SN65HVD230/231/232 are pin-compatible (but not functionally identical) with one another and, depending upon the application, may be used with identical circuit boards.

These transceivers feature 3.3-V operation and standard compatibility with signaling rates up to 1 Mbps, and also offer 16-kV HBM ESD protection on the bus pins, thermal shutdown protection, bus fault protection, and open-circuit receiver failsafe. The fail-safe design of the receiver assures a logic high at the receiver output if the bus wires become open circuited. If a high ambient operating environment temperature or excessive output current result in thermal shutdown, the bus pins become high impedance, while the D and R pins default to a logic high.

The bus pins are also maintained in a high-impedance state during low V_{CC} conditions to ensure glitch-free power-up and power-down bus protection for hot-plugging applications. This high-impedance condition also means that an unpowered node does not disturb the bus. Transceivers without this feature usually have a very low output impedance. This results in a high current demand when the transceiver is unpowered, a condition that could affect the entire bus.

OPERATING MODES

R_S (pin 8) of the SN65HVD230 and SN65HVD231 provides for three different modes of operation: high-speed mode, slope-control mode, and low-power mode.

High-Speed

The high-speed mode can be selected by applying a logic low to R_S (pin 8). The high-speed mode of operation is commonly employed in industrial applications. High-speed allows the output to switch as fast as possible with no internal limitation on the output rise and fall slopes. The only limitations of the high-speed operation are cable length and radiated emission concerns, each of which is addressed by the slope control mode of operation.

If the low-power standby mode is to be employed in the circuit, direct connection to a DSP output pin can be used to switch between a logic-low level ($< 1\text{ V}$) for high speed operation, and the logic-high level ($> 0.75\text{ V}_{CC}$) for standby. Figure 30 shows a typical DSP connection, and Figure 31 shows the HVD230 driver output signal in high-speed mode on the CAN bus.

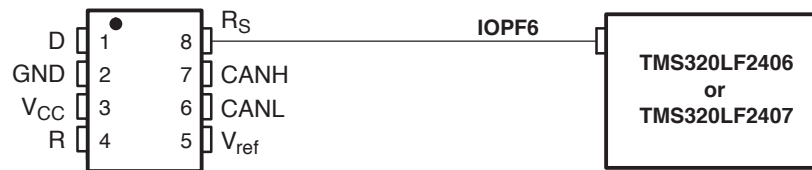

Figure 30. R_S (Pin 8) Connection to a TMS320LF2406/07 for High Speed/Standby Operation

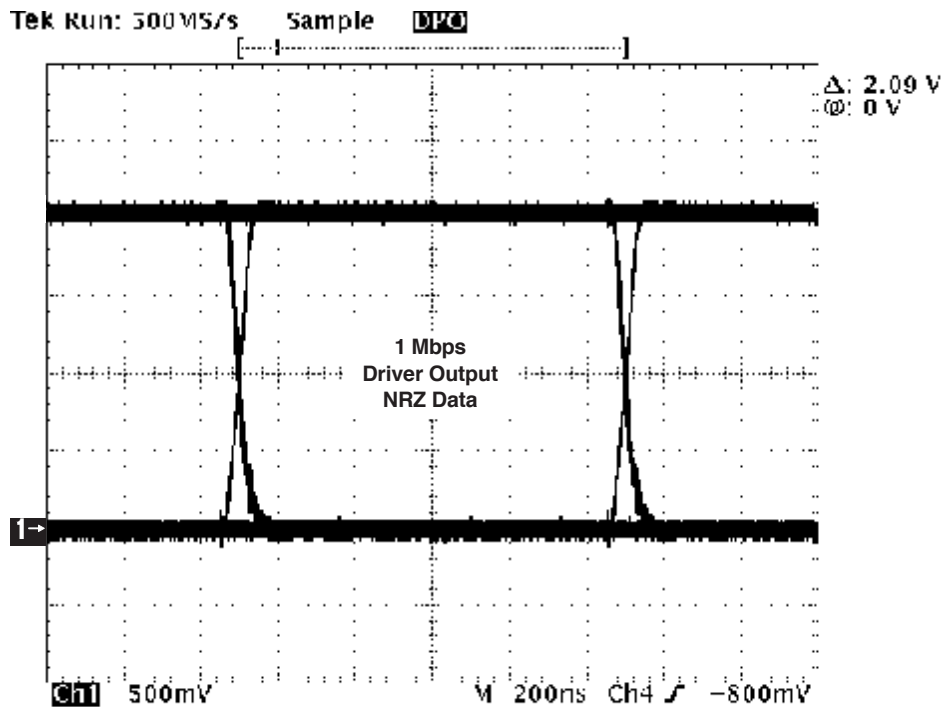

Figure 31. Typical High Speed SN65HVD230 Output Waveform Into a 60- Ω Load

Slope Control

Electromagnetic compatibility is essential in many applications using unshielded bus cable to reduce system cost. To reduce the electromagnetic interference generated by fast rise times and resulting harmonics, the rise and fall slopes of the SN65HVD230 and SN65HVD231 driver outputs can be adjusted by connecting a resistor

from R_S (pin 8) to ground or to a logic low voltage, as shown in Figure 32. The slope of the driver output signal is proportional to the pin's output current. This slope control is implemented with an external resistor value of 10 k Ω to achieve a ≈ 15 V/ μ s slew rate, and up to 100 k Ω to achieve a ≈ 2.0 V/ μ s slew rate as displayed in Figure 33. Typical driver output waveforms from a pulse input signal with and without slope control are displayed in Figure 34. A pulse input is used rather than NRZ data to clearly display the actual slew rate.

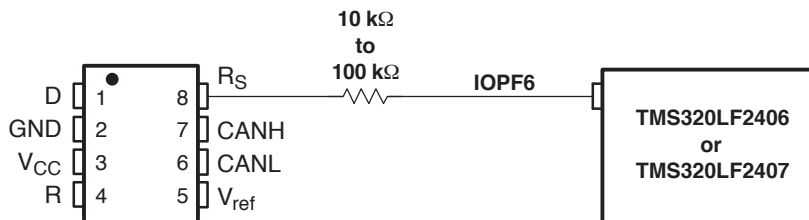

Figure 32. Slope Control/Standby Connection to a DSP

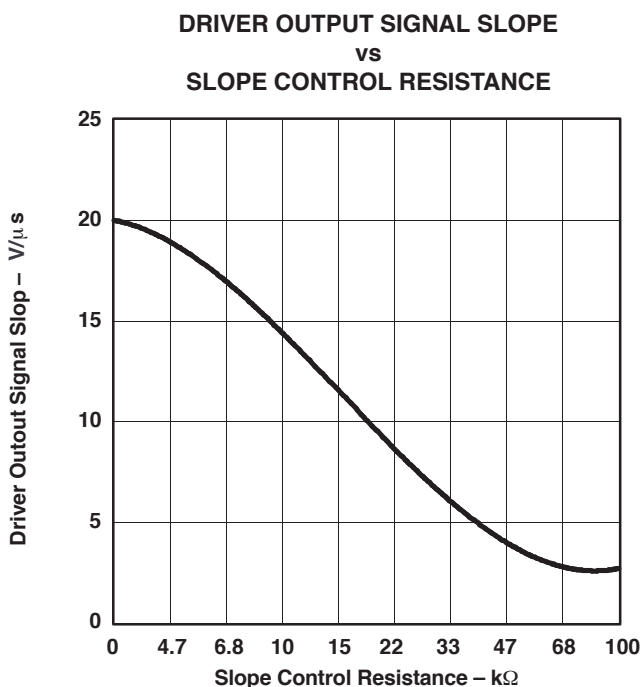

Figure 33. HVD230 Driver Output Signal Slope vs Slope Control Resistance Value

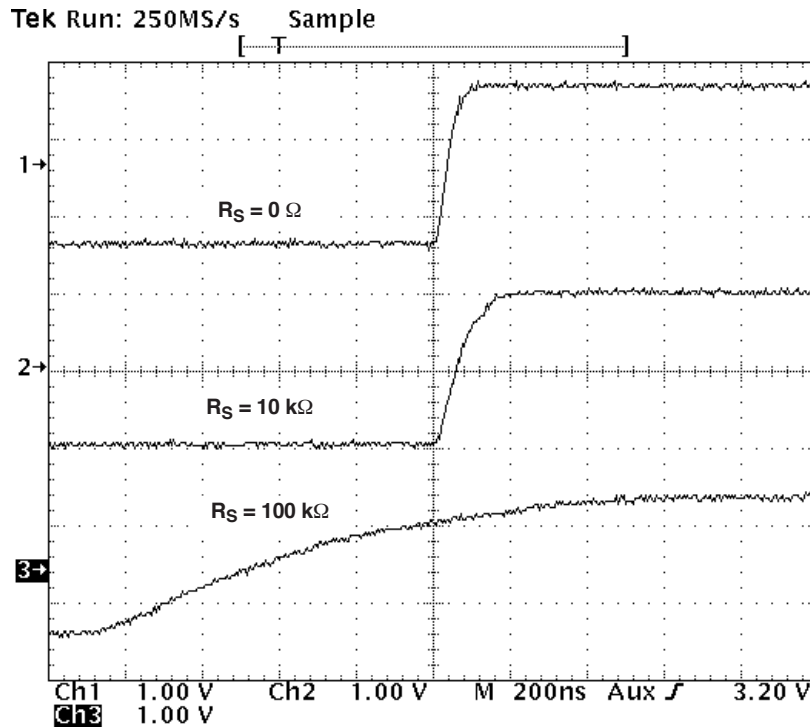

Figure 34. Typical SN65HVD230 250-kbps Output Pulse Waveforms With Slope Control

Standby Mode (Listen Only Mode) of the HVD230

If a logic high ($> 0.75 V_{CC}$) is applied to R_S (pin 8) in [Figure 30](#) and [Figure 32](#), the circuit of the SN65HVD230 enters a low-current, *listen only* standby mode, during which the driver is switched off and the receiver remains active. In this *listen only* state, the transceiver is completely passive to the bus. It makes no difference if a slope control resistor is in place as shown in [Figure 32](#). The DSP can reverse this low-power standby mode when the rising edge of a dominant state (bus differential voltage > 900 mV typical) occurs on the bus. The DSP, sensing bus activity, reactivates the driver circuit by placing a logic low (< 1.2 V) on R_S (pin 8).

The Babbling Idiot Protection of the HVD230

Occasionally, a runaway CAN controller unintentionally sends messages that completely tie up the bus (what is referred to in CAN jargon as a babbling idiot). When this occurs, the DSP can engage the *listen-only* standby mode to disengage the driver and release the bus, even when access to the CAN controller has been lost. When the driver circuit is deactivated, its outputs default to a high-impedance state.

Sleep Mode of the HVD231

The unique difference between the SN65HVD230 and the SN65HVD231 is that both driver and receiver are switched off in the SN65HVD231 when a logic high is applied to R_S (pin 8). The device remains in a very low power-sleep mode until the circuit is reactivated with a logic low applied to R_S (pin 8). While in this sleep mode, the bus-pins are in a high-impedance state, while the D and R pins default to a logic high.

LOOP PROPAGATION DELAY

Transceiver loop delay is a measure of the overall device propagation delay, consisting of the delay from the driver input to the differential outputs, plus the delay from the receiver inputs to its output.

The loop delay of the transceiver displayed in [Figure 35](#) increases accordingly when slope control is being used. This increased loop delay means that the total bus length must be reduced to meet the CAN bit-timing requirements of the overall system. The loop delay becomes ≈ 100 ns when employing slope control with a 10-k Ω resistor, and ≈ 500 ns with a 100-k Ω resistor. Therefore, considering that the rule-of-thumb propagation

delay of typical bus cable is 5 ns/m, slope control with the 100-k Ω resistor decreases the allowable bus length by the difference between the 500-ns max loop delay and the loop delay with no slope control, 70.7 ns. This equates to (500-70.7 ns)/5 ns, or approximately 86 m less bus length. This slew-rate/bus length trade-off to reduce electromagnetic interference to adjoining circuits from the bus can also be solved with a quality shielded bus cable.

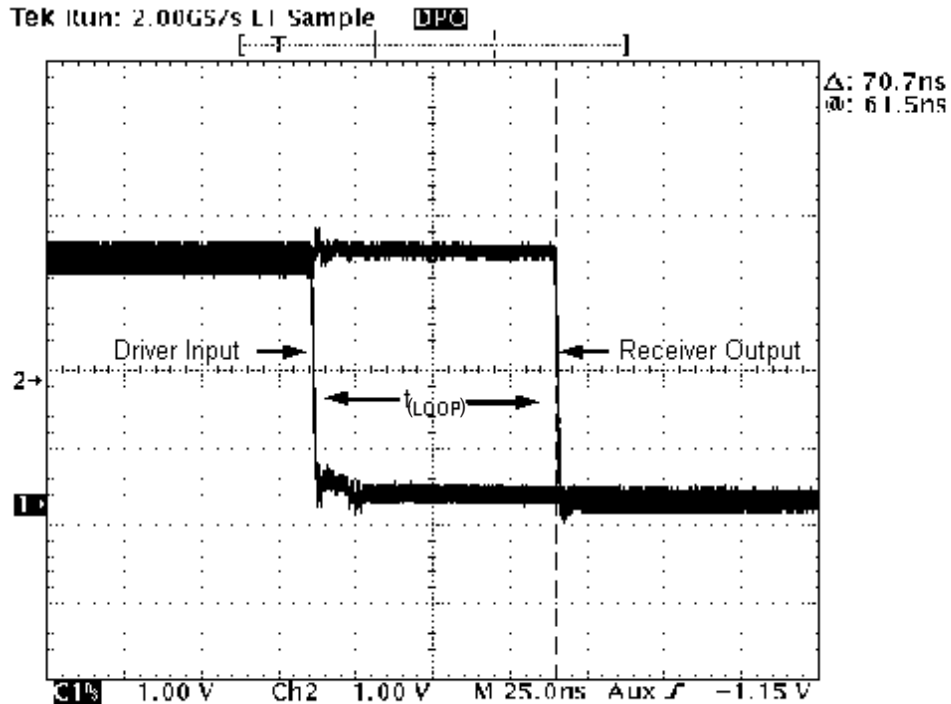

Figure 35. 70.7-ns Loop Delay Through the HVD230 With $R_S = 0$

ISO 11898 COMPLIANCE OF SN65HVD230 FAMILY OF 3.3-V CAN TRANSCEIVERS

Introduction

Many users value the low power consumption of operating their CAN transceivers from a 3.3 V supply. However, some are concerned about the interoperability with 5-V supplied transceivers on the same bus. This report analyzes this situation to address those concerns.

Differential Signal

CAN is a differential bus where complementary signals are sent over two wires and the voltage difference between the two wires defines the logical state of the bus. The differential CAN receiver monitors this voltage difference and outputs the bus state with a single-ended output signal.

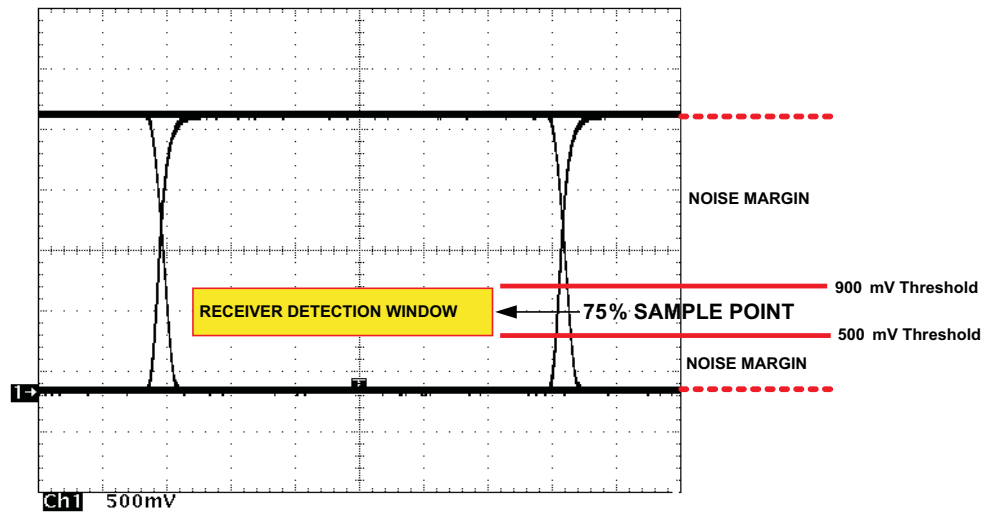

Figure 36. Typical SN65HVD230 Differential Output Voltage Waveform

The CAN driver creates the difference voltage between CANH and CANL in the dominant state. The dominant differential output of the SN65HVD230 is greater than 1.5 V and less than 3 V across a 60-ohm load. The minimum required by ISO 11898 is 1.5 V and maximum is 3 V. These are the same limiting values for 5 V supplied CAN transceivers. The bus termination resistors drive the recessive bus state and not the CAN driver.

A CAN receiver is required to output a recessive state with less than 500 mV and a dominant state with more than 900 mV difference voltage on its bus inputs. The CAN receiver must do this with common-mode input voltages from -2 V to 7 volts. The SN65HVD230 family receivers meet these same input specifications as 5-V supplied receivers.

Common-Mode Signal

A common-mode signal is an average voltage of the two signal wires that the differential receiver rejects. The common-mode signal comes from the CAN driver, ground noise, and coupled bus noise. Obviously, the supply voltage of the CAN transceiver has nothing to do with noise. The SN65HVD230 family driver lowers the common-mode output in a dominant bit by a couple hundred millivolts from that of most 5-V drivers. While this does not fully comply with ISO 11898, this small variation in the driver common-mode output is rejected by differential receivers and does not effect data, signal noise margins or error rates.

Interoperability of 3.3-V CAN in 5-V CAN Systems

The 3.3-V supplied SN65HVD23x family of CAN transceivers are electrically interchangeable with 5-V CAN transceivers. The differential output is the same. The recessive common-mode output is the same. The dominant common-mode output voltage is a couple hundred millivolts lower than 5-V supplied drivers, while the receivers exhibit identical specifications as 5-V devices.

Electrical interoperability does not assure interchangeability however. Most implementers of CAN buses recognize that ISO 11898 does not sufficiently specify the electrical layer and that strict standard compliance alone does not ensure interchangeability. This comes only with thorough equipment testing.

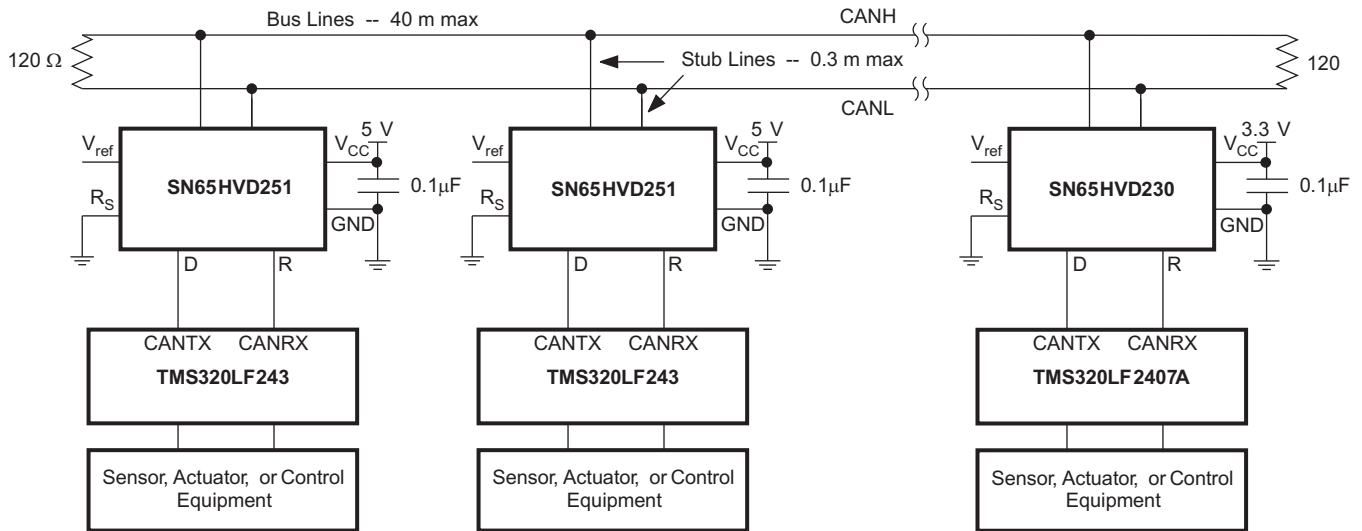

Figure 37. 3.3-V and 5-V CAN Transceiver System

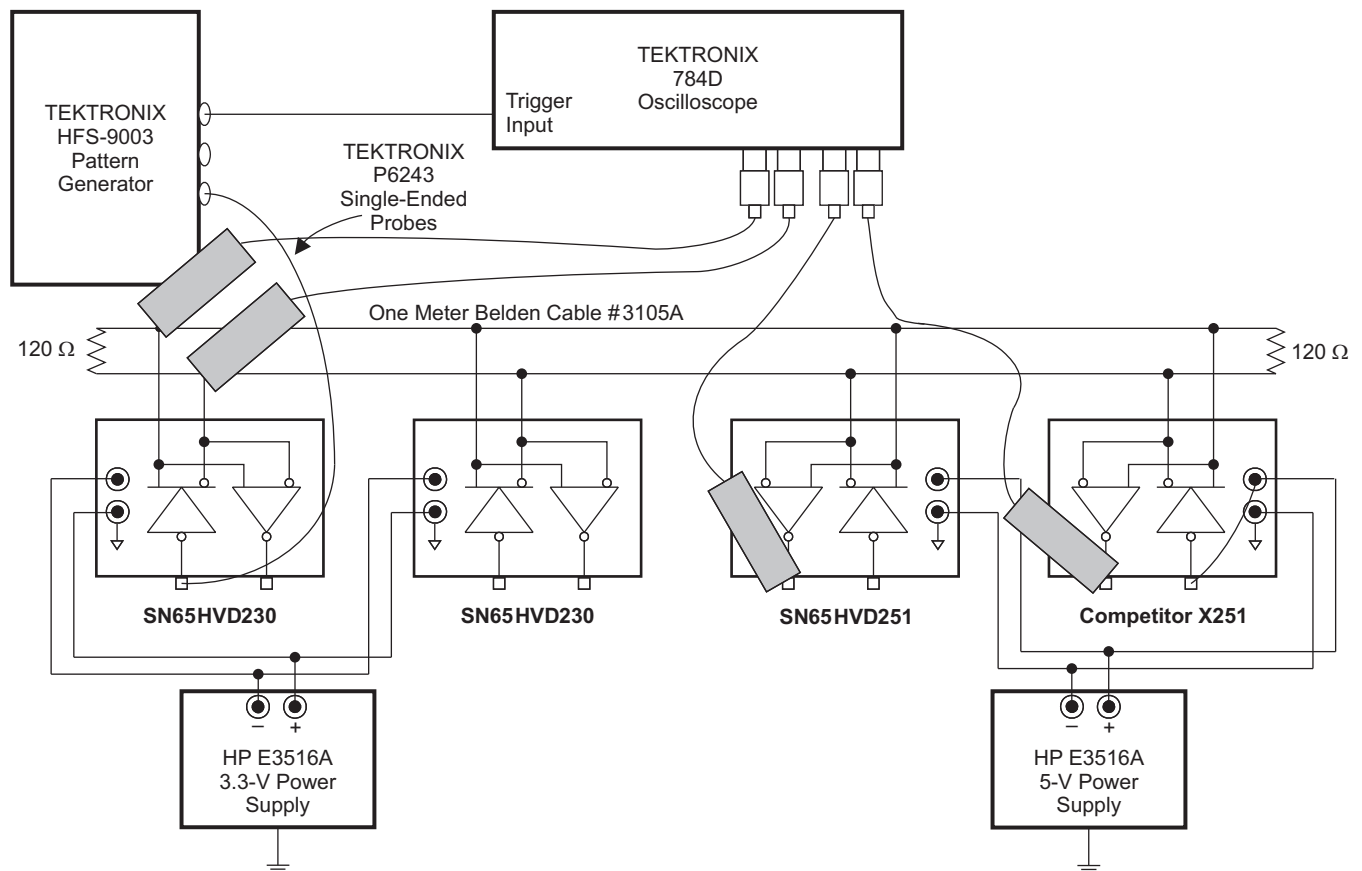

Figure 38. 3.3-V and 5-V CAN Transceiver System Testing

REVISION HISTORY

Changes from Revision I (October 2007) to Revision J	Page
• Deleted Low-to-High Propagation Delay Time vs Common-Mode Input Voltage Characteristics	17
• Deleted Driver Schematic Diagram	17
• Added Figure 37	25
• Added Figure 38	25

Changes from Revision J (January 2009) to Revision K	Page
• Replaced the DISSIPATION RATING TABLE with the Thermal Information table	6

PACKAGING INFORMATION

Orderable Device	Status (1)	Package Type	Package Drawing	Pins	Package Qty	Eco Plan (2)	Lead/Ball Finish	MSL Peak Temp (3)	Op Temp (°C)	Top-Side Markings (4)	Samples
SN65HVD230D	ACTIVE	SOIC	D	8	75	Green (RoHS & no Sb/Br)	CU NIPDAU	Level-1-260C-UNLIM	-40 to 85	VP230	Samples
SN65HVD230DG4	ACTIVE	SOIC	D	8	75	Green (RoHS & no Sb/Br)	CU NIPDAU	Level-1-260C-UNLIM	-40 to 85	VP230	Samples
SN65HVD230DR	ACTIVE	SOIC	D	8	2500	Green (RoHS & no Sb/Br)	CU NIPDAU	Level-1-260C-UNLIM	-40 to 85	VP230	Samples
SN65HVD230DRG4	ACTIVE	SOIC	D	8	2500	Green (RoHS & no Sb/Br)	CU NIPDAU	Level-1-260C-UNLIM	-40 to 85	VP230	Samples
SN65HVD231D	ACTIVE	SOIC	D	8	75	Green (RoHS & no Sb/Br)	CU NIPDAU	Level-1-260C-UNLIM	-40 to 85	VP231	Samples
SN65HVD231DG4	ACTIVE	SOIC	D	8	75	Green (RoHS & no Sb/Br)	CU NIPDAU	Level-1-260C-UNLIM	-40 to 85	VP231	Samples
SN65HVD231DR	ACTIVE	SOIC	D	8	2500	Green (RoHS & no Sb/Br)	CU NIPDAU	Level-1-260C-UNLIM	-40 to 85	VP231	Samples
SN65HVD231DRG4	ACTIVE	SOIC	D	8	2500	Green (RoHS & no Sb/Br)	CU NIPDAU	Level-1-260C-UNLIM	-40 to 85	VP231	Samples
SN65HVD232D	ACTIVE	SOIC	D	8	75	Green (RoHS & no Sb/Br)	CU NIPDAU	Level-1-260C-UNLIM	-40 to 85	VP232	Samples
SN65HVD232DG4	ACTIVE	SOIC	D	8	75	Green (RoHS & no Sb/Br)	CU NIPDAU	Level-1-260C-UNLIM	-40 to 85	VP232	Samples
SN65HVD232DR	ACTIVE	SOIC	D	8	2500	Green (RoHS & no Sb/Br)	CU NIPDAU	Level-1-260C-UNLIM	-40 to 85	VP232	Samples
SN65HVD232DRG4	ACTIVE	SOIC	D	8	2500	Green (RoHS & no Sb/Br)	CU NIPDAU	Level-1-260C-UNLIM	-40 to 85	VP232	Samples

(1) The marketing status values are defined as follows:

ACTIVE: Product device recommended for new designs.

LIFEBUY: TI has announced that the device will be discontinued, and a lifetime-buy period is in effect.

NRND: Not recommended for new designs. Device is in production to support existing customers, but TI does not recommend using this part in a new design.

PREVIEW: Device has been announced but is not in production. Samples may or may not be available.

OBSOLETE: TI has discontinued the production of the device.

(2) Eco Plan - The planned eco-friendly classification: Pb-Free (RoHS), Pb-Free (RoHS Exempt), or Green (RoHS & no Sb/Br) - please check <http://www.ti.com/productcontent> for the latest availability information and additional product content details.

TBD: The Pb-Free/Green conversion plan has not been defined.

Pb-Free (RoHS): TI's terms "Lead-Free" or "Pb-Free" mean semiconductor products that are compatible with the current RoHS requirements for all 6 substances, including the requirement that lead not exceed 0.1% by weight in homogeneous materials. Where designed to be soldered at high temperatures, TI Pb-Free products are suitable for use in specified lead-free processes.

Pb-Free (RoHS Exempt): This component has a RoHS exemption for either 1) lead-based flip-chip solder bumps used between the die and package, or 2) lead-based die adhesive used between the die and leadframe. The component is otherwise considered Pb-Free (RoHS compatible) as defined above.

Green (RoHS & no Sb/Br): TI defines "Green" to mean Pb-Free (RoHS compatible), and free of Bromine (Br) and Antimony (Sb) based flame retardants (Br or Sb do not exceed 0.1% by weight in homogeneous material)

⁽³⁾ MSL, Peak Temp. -- The Moisture Sensitivity Level rating according to the JEDEC industry standard classifications, and peak solder temperature.

⁽⁴⁾ Multiple Top-Side Markings will be inside parentheses. Only one Top-Side Marking contained in parentheses and separated by a "~" will appear on a device. If a line is indented then it is a continuation of the previous line and the two combined represent the entire Top-Side Marking for that device.

Important Information and Disclaimer:The information provided on this page represents TI's knowledge and belief as of the date that it is provided. TI bases its knowledge and belief on information provided by third parties, and makes no representation or warranty as to the accuracy of such information. Efforts are underway to better integrate information from third parties. TI has taken and continues to take reasonable steps to provide representative and accurate information but may not have conducted destructive testing or chemical analysis on incoming materials and chemicals. TI and TI suppliers consider certain information to be proprietary, and thus CAS numbers and other limited information may not be available for release.

In no event shall TI's liability arising out of such information exceed the total purchase price of the TI part(s) at issue in this document sold by TI to Customer on an annual basis.

TAPE AND REEL INFORMATION

QUADRANT ASSIGNMENTS FOR PIN 1 ORIENTATION IN TAPE

*All dimensions are nominal

Device	Package Type	Package Drawing	Pins	SPQ	Reel Diameter (mm)	Reel Width W1 (mm)	A0 (mm)	B0 (mm)	K0 (mm)	P1 (mm)	W (mm)	Pin1 Quadrant
SN65HVD230DR	SOIC	D	8	2500	330.0	12.4	6.4	5.2	2.1	8.0	12.0	Q1
SN65HVD231DR	SOIC	D	8	2500	330.0	12.4	6.4	5.2	2.1	8.0	12.0	Q1
SN65HVD232DR	SOIC	D	8	2500	330.0	12.4	6.4	5.2	2.1	8.0	12.0	Q1

TAPE AND REEL BOX DIMENSIONS



*All dimensions are nominal

Device	Package Type	Package Drawing	Pins	SPQ	Length (mm)	Width (mm)	Height (mm)
SN65HVD230DR	SOIC	D	8	2500	340.5	338.1	20.6
SN65HVD231DR	SOIC	D	8	2500	340.5	338.1	20.6
SN65HVD232DR	SOIC	D	8	2500	340.5	338.1	20.6

D (R-PDSO-G8)

PLASTIC SMALL OUTLINE



- NOTES:
- A. All linear dimensions are in inches (millimeters).
 - B. This drawing is subject to change without notice.
 - C. Body length does not include mold flash, protrusions, or gate burrs. Mold flash, protrusions, or gate burrs shall not exceed 0.006 (0,15) each side.
 - D. Body width does not include interlead flash. Interlead flash shall not exceed 0.017 (0,43) each side.
 - E. Reference JEDEC MS-012 variation AA.

D (R-PDSO-G8)

PLASTIC SMALL OUTLINE

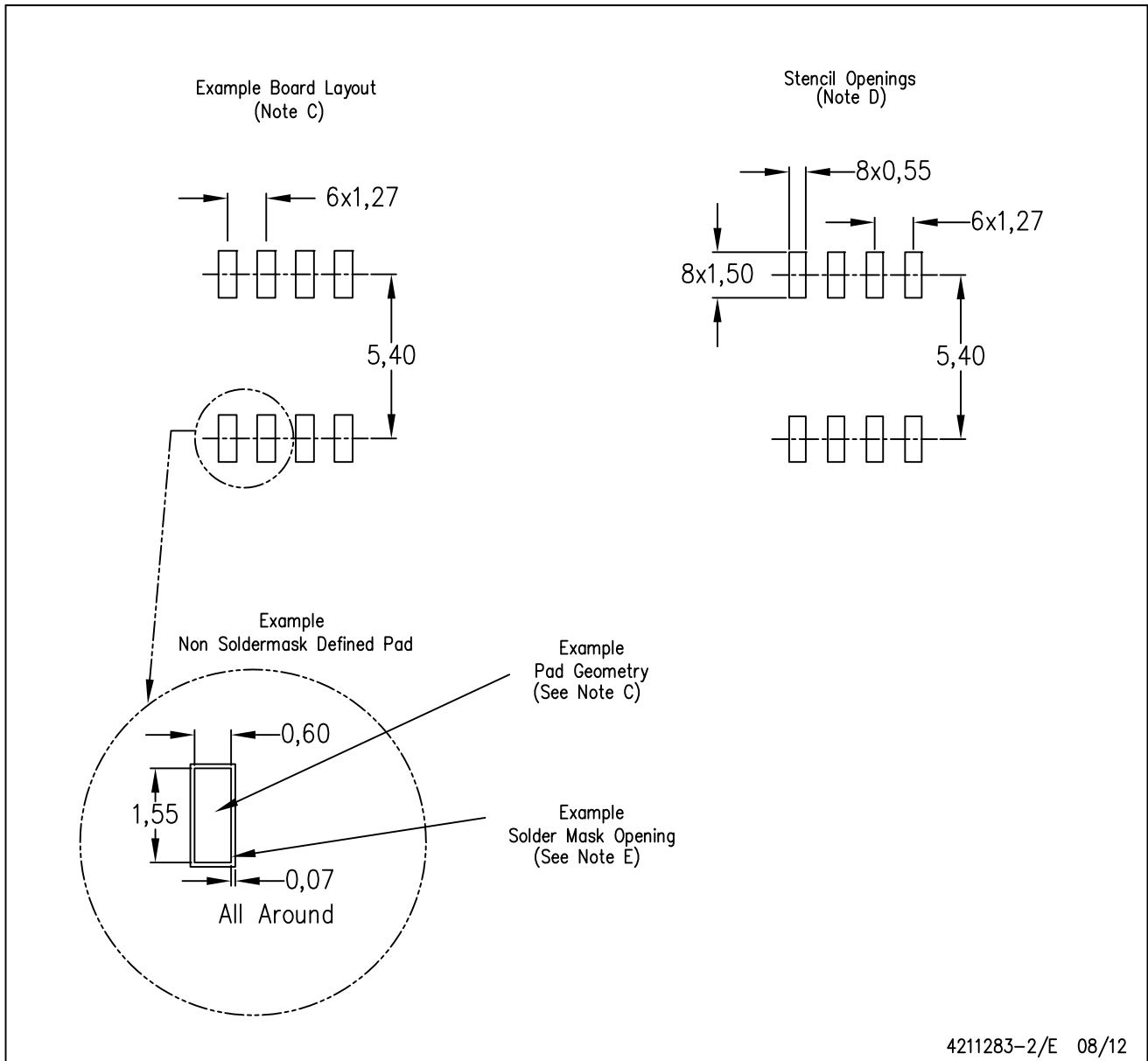

- NOTES:
- All linear dimensions are in millimeters.
 - This drawing is subject to change without notice.
 - Publication IPC-7351 is recommended for alternate designs.
 - Laser cutting apertures with trapezoidal walls and also rounding corners will offer better paste release. Customers should contact their board assembly site for stencil design recommendations. Refer to IPC-7525 for other stencil recommendations.
 - Customers should contact their board fabrication site for solder mask tolerances between and around signal pads.

IMPORTANT NOTICE

Texas Instruments Incorporated and its subsidiaries (TI) reserve the right to make corrections, enhancements, improvements and other changes to its semiconductor products and services per JESD46, latest issue, and to discontinue any product or service per JESD48, latest issue. Buyers should obtain the latest relevant information before placing orders and should verify that such information is current and complete. All semiconductor products (also referred to herein as "components") are sold subject to TI's terms and conditions of sale supplied at the time of order acknowledgment.

TI warrants performance of its components to the specifications applicable at the time of sale, in accordance with the warranty in TI's terms and conditions of sale of semiconductor products. Testing and other quality control techniques are used to the extent TI deems necessary to support this warranty. Except where mandated by applicable law, testing of all parameters of each component is not necessarily performed.

TI assumes no liability for applications assistance or the design of Buyers' products. Buyers are responsible for their products and applications using TI components. To minimize the risks associated with Buyers' products and applications, Buyers should provide adequate design and operating safeguards.

TI does not warrant or represent that any license, either express or implied, is granted under any patent right, copyright, mask work right, or other intellectual property right relating to any combination, machine, or process in which TI components or services are used. Information published by TI regarding third-party products or services does not constitute a license to use such products or services or a warranty or endorsement thereof. Use of such information may require a license from a third party under the patents or other intellectual property of the third party, or a license from TI under the patents or other intellectual property of TI.

Reproduction of significant portions of TI information in TI data books or data sheets is permissible only if reproduction is without alteration and is accompanied by all associated warranties, conditions, limitations, and notices. TI is not responsible or liable for such altered documentation. Information of third parties may be subject to additional restrictions.

Resale of TI components or services with statements different from or beyond the parameters stated by TI for that component or service voids all express and any implied warranties for the associated TI component or service and is an unfair and deceptive business practice. TI is not responsible or liable for any such statements.

Buyer acknowledges and agrees that it is solely responsible for compliance with all legal, regulatory and safety-related requirements concerning its products, and any use of TI components in its applications, notwithstanding any applications-related information or support that may be provided by TI. Buyer represents and agrees that it has all the necessary expertise to create and implement safeguards which anticipate dangerous consequences of failures, monitor failures and their consequences, lessen the likelihood of failures that might cause harm and take appropriate remedial actions. Buyer will fully indemnify TI and its representatives against any damages arising out of the use of any TI components in safety-critical applications.

In some cases, TI components may be promoted specifically to facilitate safety-related applications. With such components, TI's goal is to help enable customers to design and create their own end-product solutions that meet applicable functional safety standards and requirements. Nonetheless, such components are subject to these terms.

No TI components are authorized for use in FDA Class III (or similar life-critical medical equipment) unless authorized officers of the parties have executed a special agreement specifically governing such use.

Only those TI components which TI has specifically designated as military grade or "enhanced plastic" are designed and intended for use in military/aerospace applications or environments. Buyer acknowledges and agrees that any military or aerospace use of TI components which have *not* been so designated is solely at the Buyer's risk, and that Buyer is solely responsible for compliance with all legal and regulatory requirements in connection with such use.

TI has specifically designated certain components as meeting ISO/TS16949 requirements, mainly for automotive use. In any case of use of non-designated products, TI will not be responsible for any failure to meet ISO/TS16949.

Products

Audio	www.ti.com/audio
Amplifiers	amplifier.ti.com
Data Converters	dataconverter.ti.com
DLP® Products	www.dlp.com
DSP	dsp.ti.com
Clocks and Timers	www.ti.com/clocks
Interface	interface.ti.com
Logic	logic.ti.com
Power Mgmt	power.ti.com
Microcontrollers	microcontroller.ti.com
RFID	www.ti-rfid.com
OMAP Applications Processors	www.ti.com/omap
Wireless Connectivity	www.ti.com/wirelessconnectivity

Applications

Automotive and Transportation	www.ti.com/automotive
Communications and Telecom	www.ti.com/communications
Computers and Peripherals	www.ti.com/computers
Consumer Electronics	www.ti.com/consumer-apps
Energy and Lighting	www.ti.com/energy
Industrial	www.ti.com/industrial
Medical	www.ti.com/medical
Security	www.ti.com/security
Space, Avionics and Defense	www.ti.com/space-avionics-defense
Video and Imaging	www.ti.com/video

TI E2E Community

e2e.ti.com